

Electrostatic Particle Filter

# ESP-25



UK | Read and save these instructions!

**exodraft**  
Your energy. Optimized.

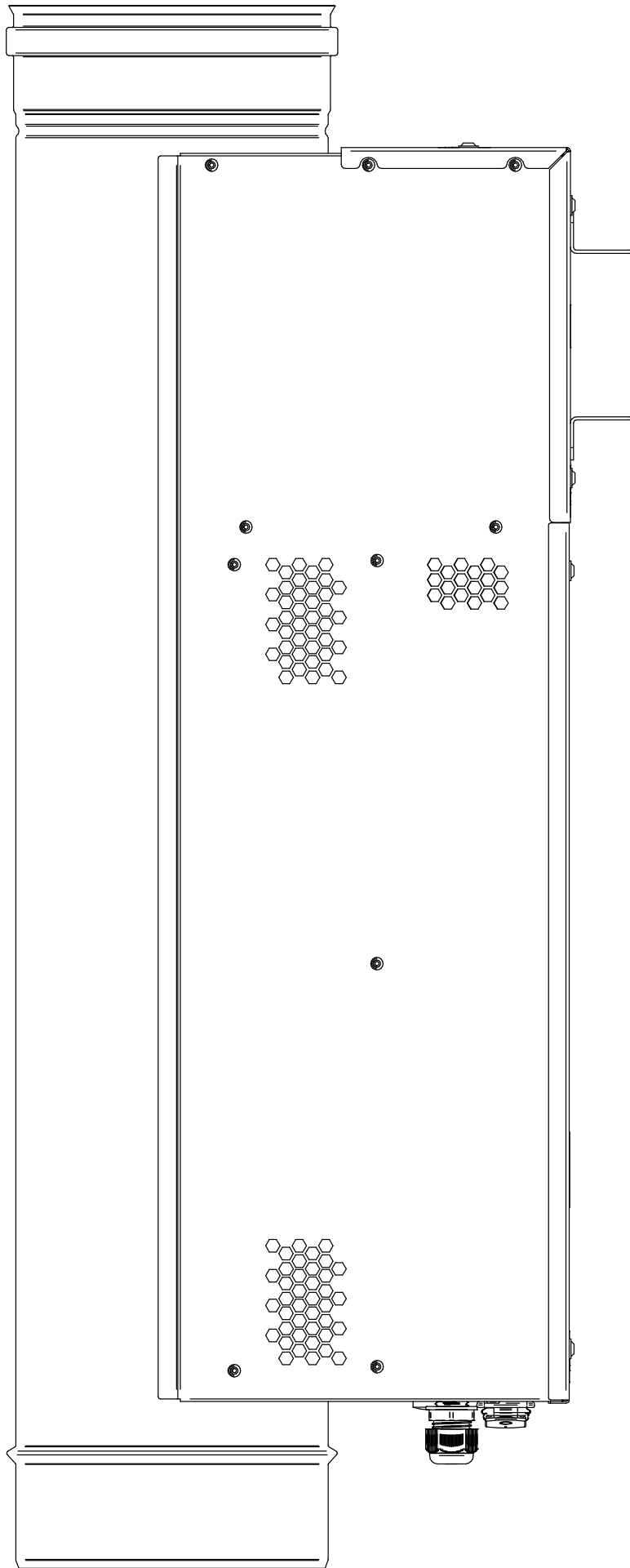

## Particle Filter | ESP-25

# Content

---

<b>Product description</b>	<b>7</b>
Scope of supply	7
Accessories and spare parts	7
Functionality of the electrostatic precipitator	8
Automatic on/off	8
Warranty	9
Technical specifications	10
Precautions and user instructions	12
<b>Mechanical installation</b>	<b>13</b>
Positioning of the ESP-25	13
Before installation in a chimney construction	14
Installation in a chimney construction	16
<b>Controller</b>	<b>18</b>
<b>Electrical installation</b>	<b>19</b>
<b>Start-up and configuration</b>	<b>21</b>
General	21
System test	21
<b>User operation instructions</b>	<b>22</b>
User operation	22
Indications on the ESP-25	23
<b>Maintenance and troubleshooting</b>	<b>24</b>
Safety precautions	24
User maintenance	25
Inspection and service	26
Cleaning procedure - performed by user	28
Chimney sweeping - performed by chimney sweeper	29
Troubleshooting	30
Other problems and solutions	30
<b>UK Conformity Assessed</b>	<b>31</b>
<b>Declaration of Conformity</b>	<b>32</b>



## How to use this manual

*This manual has been prepared based on the specific product and contains relevant technical information and installations guides.*

*Accessories and spare parts are not covered by this manual. Please refer to the individual manuals of these components.*

*This installation manual does not contain any system design documentation.*

*Failure to observe instructions marked with a danger symbol may result in personal injury and/or damage to the product.*

Errors and omissions excepted.



## Disposal

Electrical and electronic equipment (EEE) often contain materials, components and substances that may harm the environment or be hazardous to your health. Products (WEEE) marked with the 'crossed-out wheeled bin' symbol should be disposed of separately from other waste at the end of its life. Though legislation may differ from country to country we strongly advise that electrical and electronic waste is separated from other waste and disposed of according to national legislation to protect the environment and personnel that may come into contact with waste.

# Symbols

The following symbols may be used in the manual to draw attention to danger or risk of personal injury or damage to the product.



## General prohibition

Failure to observe instructions marked with the prohibited symbol may result in extreme danger or serious personal injury.



## General attention

Marks a dangerous situation that, in the worst-case scenario, can cause serious personal injury or significant damage to the product.



## General warning

Failure to observe instructions marked with a danger symbol may result in personal injury and/or damage to the product.



## Electricity hazard/High Voltage

Marks a situation in which caution is advised due to the risk of high voltage electric shock which can cause serious personal injury or significant damage to the product.



## Connect an earth terminal to the ground

Failure to observe instructions marked with a danger symbol may result in personal injury and/or damage to the product.



## Permitted and approved

Permitted and approved method of installation.



## Prohibited and not approved

Prohibited and not approved method of installation.



## Warning

To minimise the risk of fire, electric shock, personal injury and/or damage to the product please observe the following:

- Please always read the manual and only use the product in accordance with the manufacturer's instructions. If in doubt, contact one of the Exodraft specialized dealers.
- All installations must be carried out by properly qualified personnel in accordance with national legislation and regulations.
- This product must be earthed. Get assistance from an qualified electrician when in doubt.
- Ensure that the chimney has been swept before mounting the filter to avoid chimney fire.
- The product must be accessible for service and maintenance.
- Prior to servicing the product, disconnect the power supply to the filter. Turn off the main switch located on the filter. Ensure that the heat source and the filter cannot be turned on accidentally. Let the filter cool down before service or cleaning.
- Automatic power on/off function; when connected to a pellet boiler, high voltage is switched on, when the pellet boiler starts. Touching the electrode or the electrode holder may be fatal.
- Exodraft always recommends the use of a smoke alarm when a solid fuel fireplace is installed.
- If the Exodraft fan system has been designed for solid fuel/multi fuel installations, please ensure that the design meets the requirements of BS EN15287-1. If this cannot be achieved, a smoke alarm must be installed in the same room as the heat appliance.
- Undesirable stoking practice may result in problems, such as excessive soot accumulation, chimney fires, etc., which may damage the product.

## Product description

The ESP-25 is an electrostatic precipitator (particle filter) for pellet boilers for inline installation in indoor chimney constructions and is placed directly after the pellet boiler. The ESP-25 is designed to reduce the level of particles from pellet boilers.

The ESP-25 is intended for non-condensing pellet boilers with a maximum heating output of no more than 25 kW and can only be used on chimney constructions with negative pressure.

The ESP-25 is supplied on a standard Ø150 uninsulated flue, with a 5-metre-long supply cable with stripped conductors for plug installation.

If the pellet boiler is not adjusted for proper combustion, it may cause problems with soot, chimney fires, etc., which may damage the product. Please follow the instructions from the manufacturer of the pellet boiler.

## Scope of supply

- ESP-25 with 5-metre connection cable (with stripped conductors)
- Installation manual and user instructions
- Cleaning brush and handle
- Brush stop
- 3x Warning labels

**An adapter for mounting the ESP-25 in an existing chimney must be ordered separately.**

## Accessories and spare parts

The table below shows the accessories and spare parts available for the ESP-25 model.

Accessories*	Spare parts
Adapters**	Electrode
	Insulator
	Controller
	Cleaning brush

\*This manual does not describe the specific use of accessories. We refer to the separate manuals for such components.

For more details contact your Exodraft dealer.

\*\*Following adapters are currently available:

- Ø150 double male
- Ø150 double female
- Ø130-Ø150 double male increaser
- Ø130-Ø150 double female increaser

For other types we refer to suppliers of chimney adapters, for example chimney manufactures.

## Functionality of the electrostatic precipitator

ESP-25 is an electrostatic precipitator that reduces the number of fine and ultra-fine particles in a flue gas stream by creating an electrostatic field between the charging and collecting electrodes.

The electrostatic field is generated by the charging electrode which is connected to a high voltage controller which ionises the surrounding gas, consequently charging the particles and creating an electrostatic field strong enough to push the charged particles towards the flue (collecting electrode). The flue gas particles are captured and retained in the electrostatic field and can be removed when the filter is cleaned.

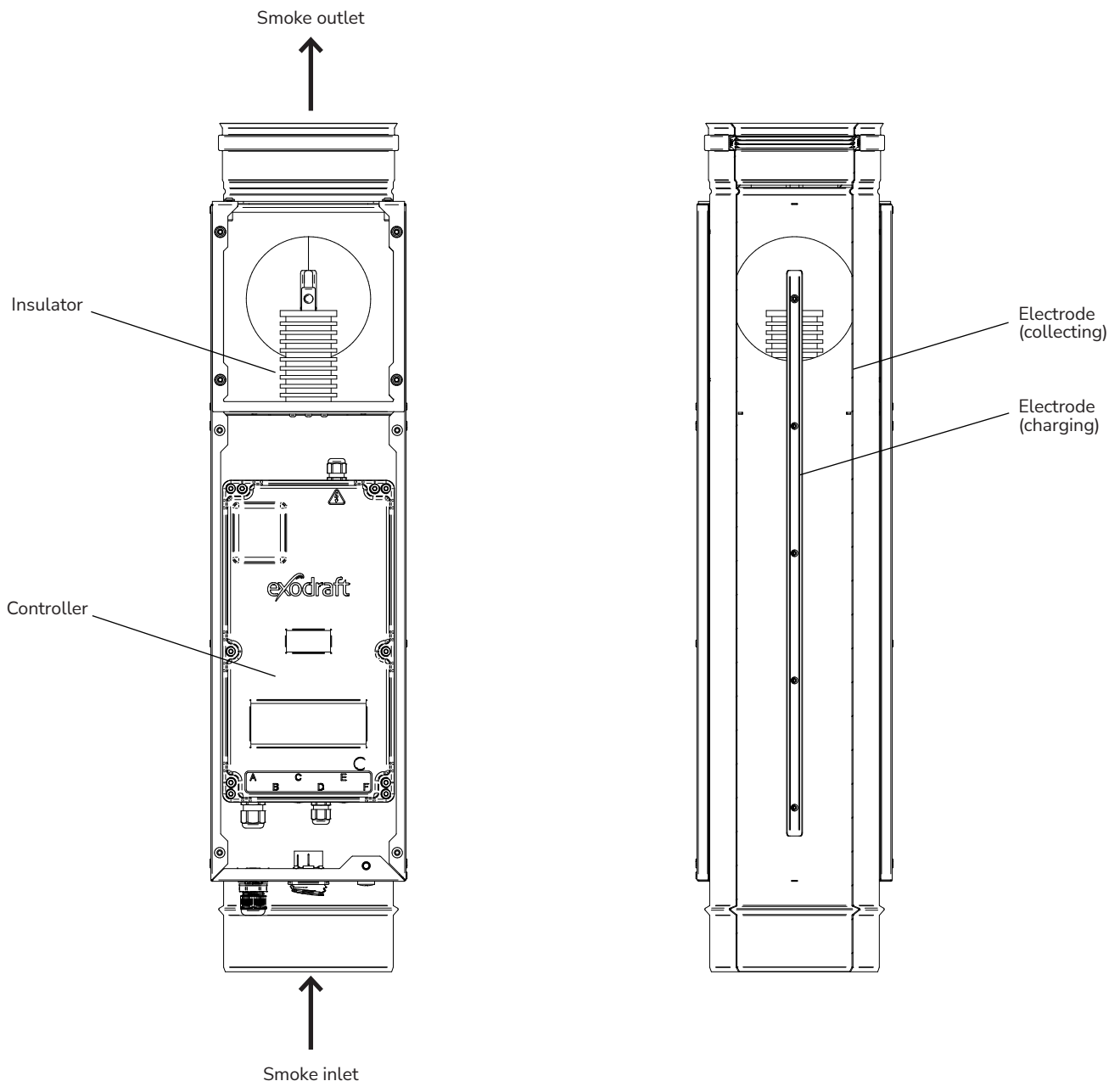

## Automatic on/off

It is possible to connect the ESP-25 to the pellet boiler so that it receives an automatic start/stop signal and standby mode if there is an available and suitable electrical output on the pellet boiler that switches on and off with the boiler. See **Electrical installation**.



## Warranty

All Exodraft products are covered by a 2-year guarantee as per European consumer rights legislation. For some countries an extended period of guarantee may apply depending on either national legislation or other clearly stipulated conditions. Customer complaints must be handled by a specialised dealer or wholesaler (preferably where the Exodraft product has been bought originally). An updated list of Exodraft specialised dealers can be found on our website for the country in question.

Exodraft products must always be installed by properly qualified personnel. Exodraft reserves the right to change these guidelines without prior notice.

The warranty and liability does not cover instances regarding personal injury or damage to property or the product that can be ascribed to one or more of the following causes:

- Failure to follow this installation and operation manual
- Incorrect installation, start-up, maintenance or servicing
- Improper repairs
- Unauthorised structural modifications made to the product
- Installation of additional components that have not been tested/approved with the product
- Any damage resulting from continued use of the product despite an evident defect
- Failure to use original spareparts and accessories
- Failure to use the product as intended
- Exceeding or failure to meet the limit values in the technical data
- Force majeure

## Technical specifications

Model	Motor specifications					
	V	Amp	Hz	Power consumption in use [W]	Power consumption standby [W]	High Voltage [kV/mA]*
ESP-25	1 x 115 - 230	0.5	50 - 60	20 - 50	2	30 / 1.7

\*Power consumption at min. ambient temperature of -20°C and max. ambient temperature of 35°C.

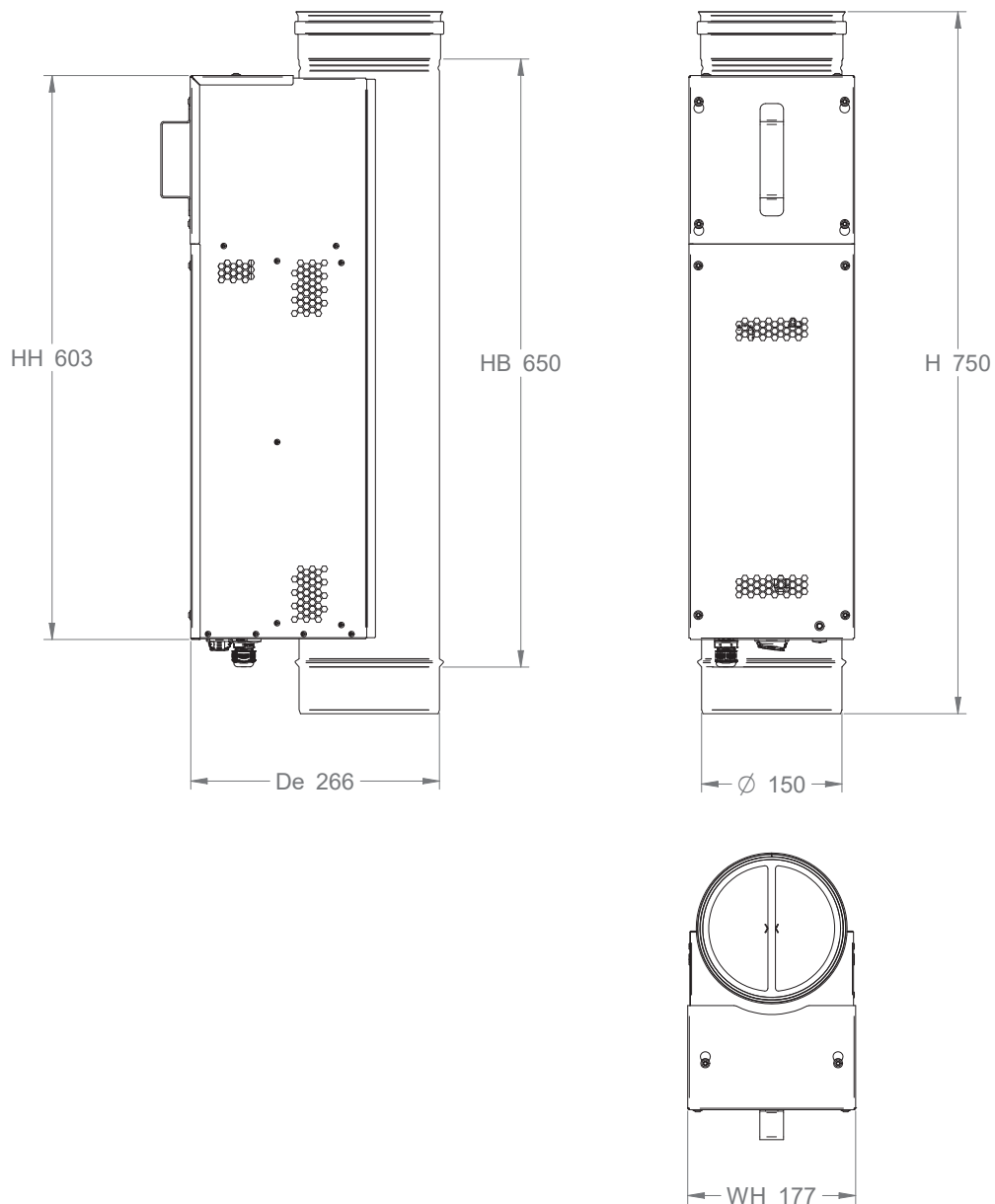

Model	Weight	Dimension [mm]					
	kg	H	HB	HH	WH	DE	Ø
ESP-25	8	750	650	603	177	266	150

## Construction and components

1	Upper lid
2	Lower lid
3	Insulator
4	Electrode

5	Controller
6	Main Switch
7	Inlet for smoke
8	Outlet for smoke

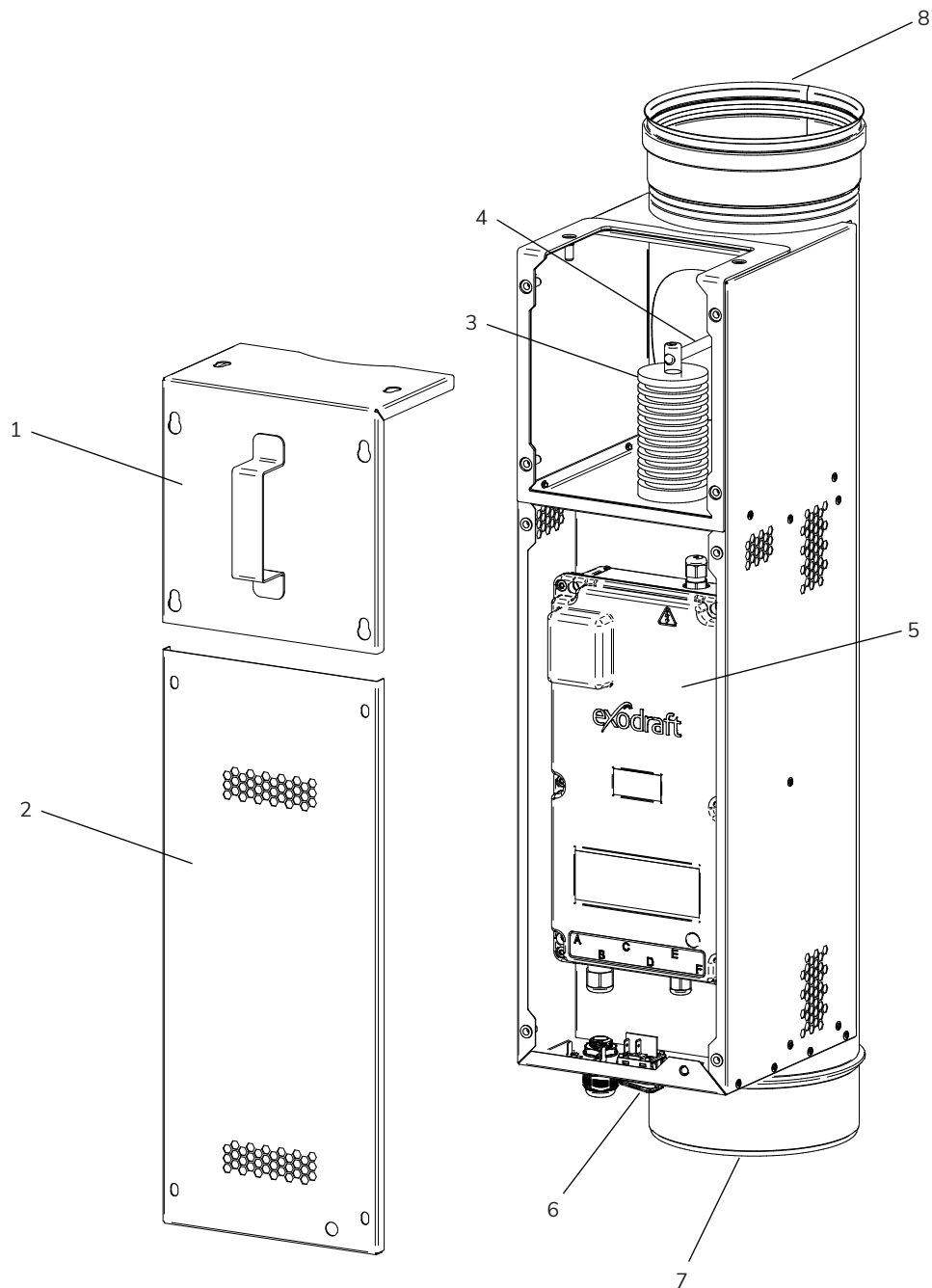

## Precautions and user instructions

These instructions, applicable standards and the manufacturer's relevant safety procedures must be followed, together with the official provisions in force in the country where the product is installed.

### System type

The ESP-25 is only intended for installation in combination with non-condensing pellet boilers with a maximum heating output of no more than 25 kW and can only be used on chimney constructions with negative pressure.

Chimney type	Specifications				
	Application	Boiler performance range [kW]	Maximum flue gas temperature [°C]	Minimum size [mm]	Maximum size [mm]
Steel (round)	Pellet boilers (non-condensing)	2 – 25	200 (250 shortly)	Ø130	Ø150

### Precautions

Be aware that the ESP-25

- must be mounted with the approved Exodraft accessories.
- must be accessible for service and maintenance from the boiler room.
- must be installed at least 500 mm from flammable materials.
- must be installed at least 500 mm from the boiler due to possible thermal exposure.
- must only be installed on a chimney construction that can support its weight.
- must only be installed on a chimney construction that is not leaking.

Other recommendations

- it is recommended that the chimney is swept and any deposits and blockages are removed before installation.
- it is recommended that a smoke alarm is always installed together with a pellet-fired system.

## Mechanical installation

Exodraft products must always be installed by properly qualified personnel and according to the manufacturer's instructions. Installation of the ESP-25 must be done in consultation with your chimney sweeper.

As the ESP-25 is installed as part of a pellet boiler system, the user must ensure that the design meets the relevant requirements of the country/region.

### Positioning of the ESP-25

- Must be installed in the pellet boiler system's existing chimney system.
- Must be installed in steel chimney systems. See diameter constraints under **System type**.
- Must be installed in chimney systems with an approved adapter (if an adapter is necessary).
- Must be accessible for service and maintenance by standing on the ground or using a ladder.
- Must be positioned so that the viewing angle of the LED is visible from the operating side of the pellet boiler.
- Must only be mounted in a vertical position. **DO NOT MOUNT HORIZONTALLY.**

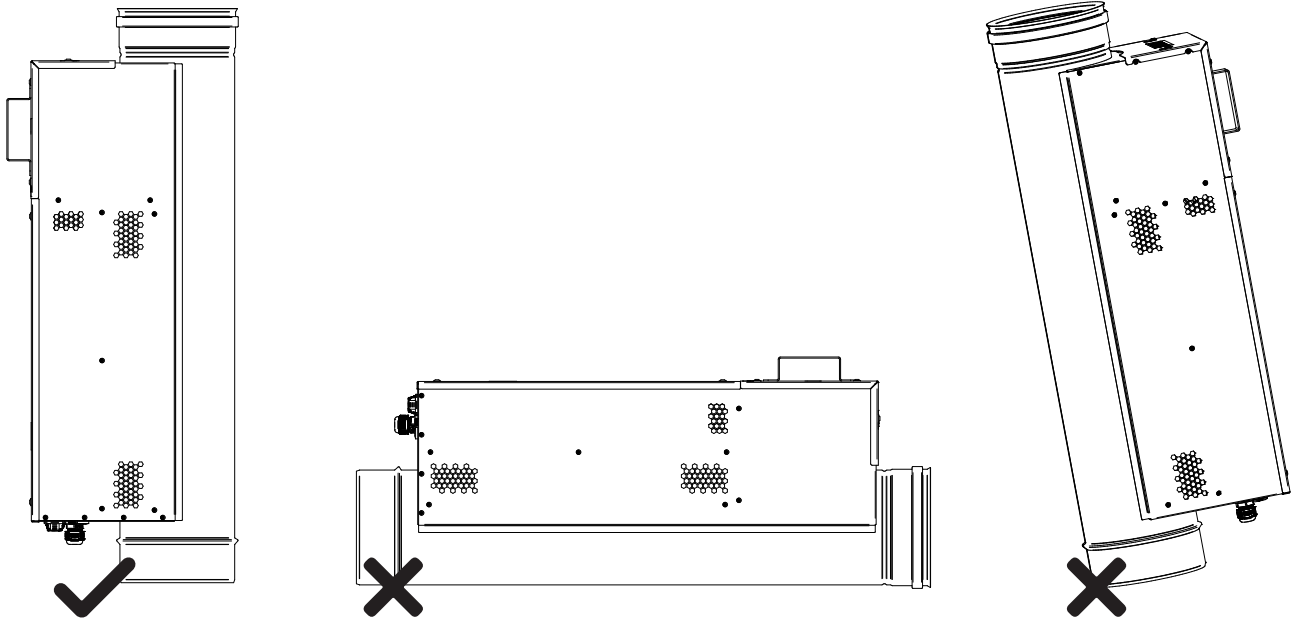

## Before installation in a chimney construction

Before installation of the ESP-25, it must be ensured that the electrode is in the correct position. If the electrode is out of its correct position, the electrostatic precipitator will not function correctly.



**ATTENTION!** The power supply must always be switched off when adjusting the electrode. Touching the electrode while the power is on can be fatal.

### Aligning the electrode

Check the position of the electrode before installing the ESP-25. Check that the electrode is positioned in the centre of the flue. If the electrode is not correctly adjusted, try to readjust it by removing the top cover (6 screws, tool - TX20), then loosen the set screw (tool - 3 mm Allen key), adjust the electrode and retighten the set screw.

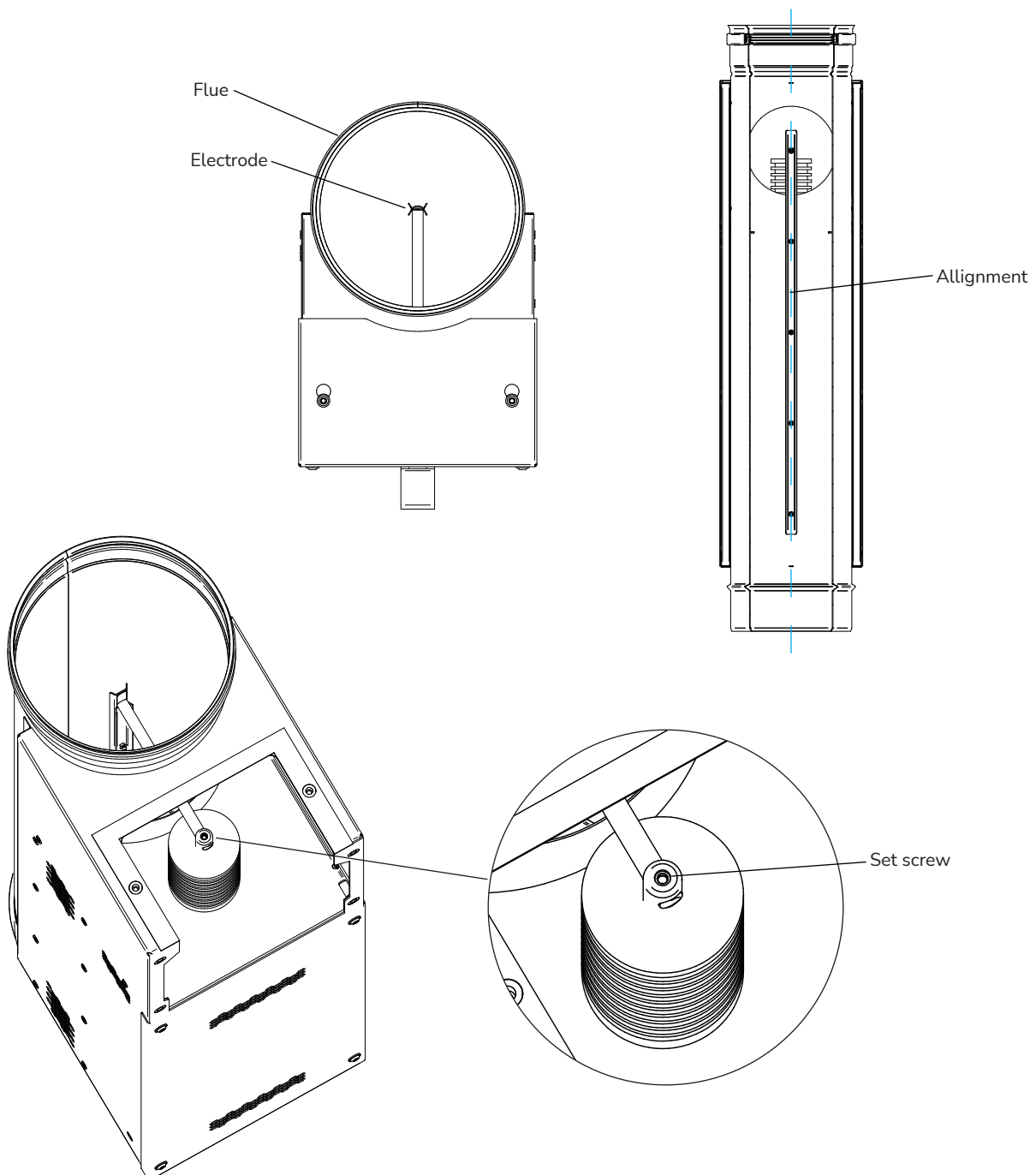

## Brush stop

The supplied brush stop must be used in installations where the chimney sweeper cleans the chimney from the roof and does not have access to the ESP-25 in the boiler room. The brush stop can be installed from the top. The brush stop is intended to prevent the chimney sweeper from impacting the electrode when cleaning the chimney from the roof.

The chimney sweeper must always be made aware that the chimney is fitted with an ESP-25! Please refer to sections **Attach the warning signs** and **Chimney sweeping**.

Installations where the chimney is always cleaned from below from the boiler room, the brush stop does not need to be installed. Please refer to section **Chimney sweeping**.

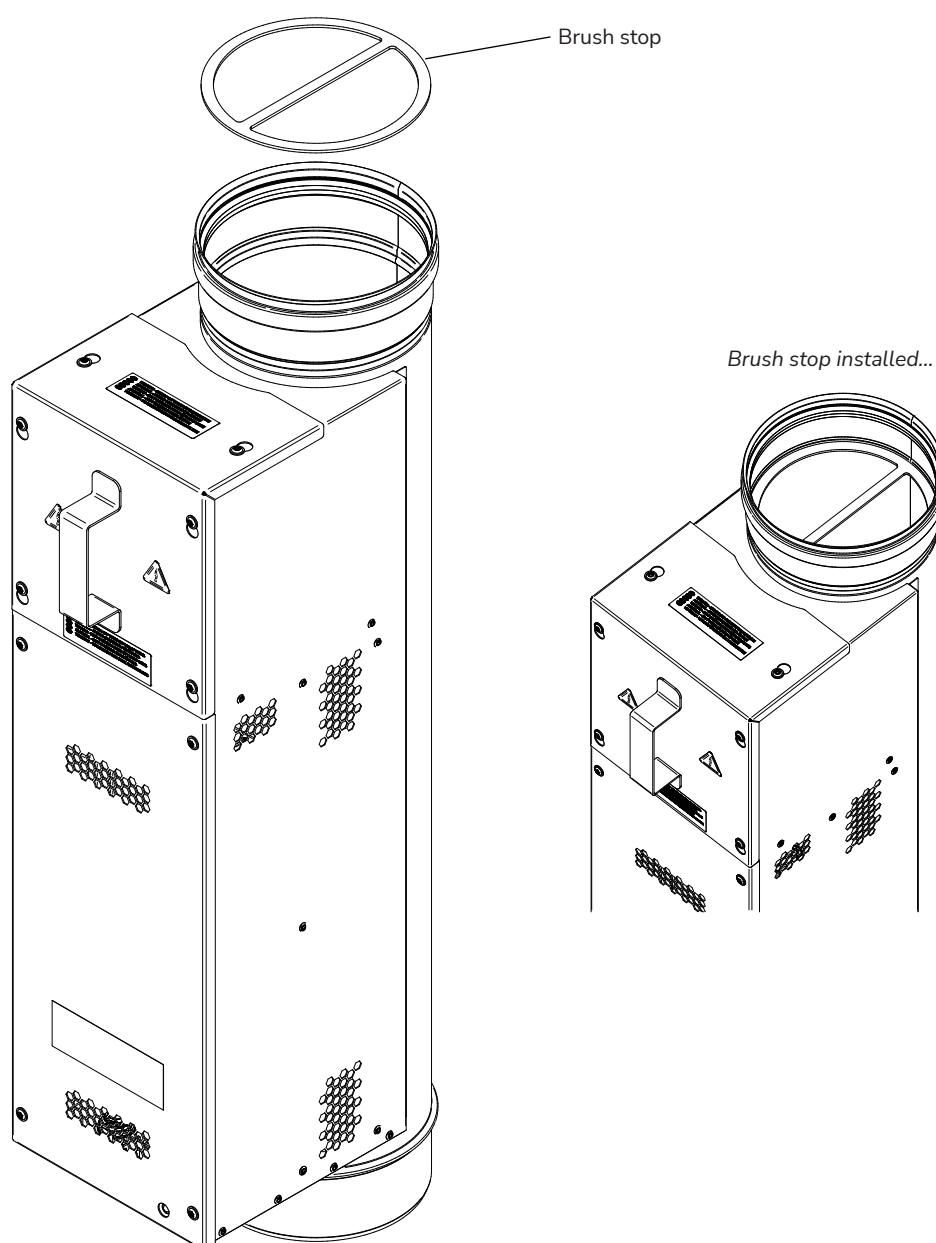

## Installation in a chimney construction

The illustrations below shows the recommended installation. Depending on the chimney system (manufacturer), adapters may be required between the ESP-25 and the flue pipes.

If installed on a boiler with rear flue outlet, it is recommended to install a Tee piece with a soot cap to remove dust either from the boiler or particles/dust collected by the ESP-25 and later deposited after the cleaning process.

If installed on a boiler with an upward flue outlet, it is recommended to install a flue pipe section with a cleaning door to remove particles/dust collected by the ESP-25 and later deposited after the cleaning process.

It is recommended that the viewing angle of the ESP-25 LED is visible from the operating side of the pellet boiler.

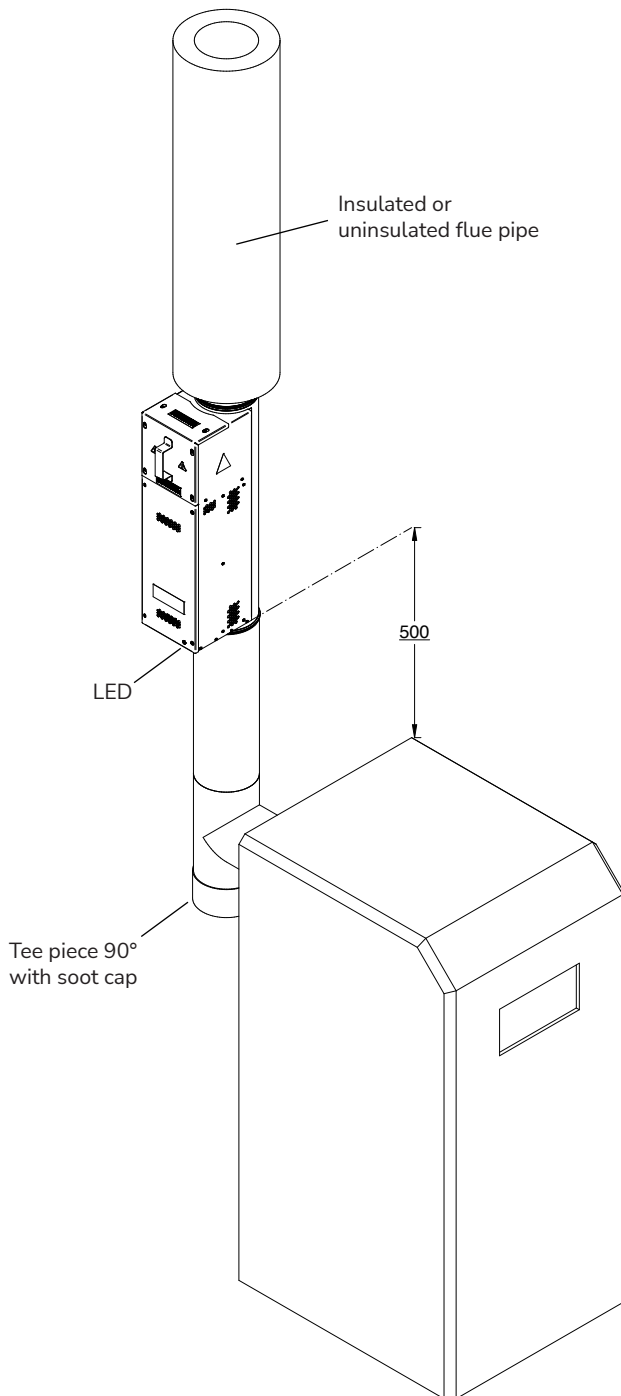

Installation on boiler with rear flue outlet

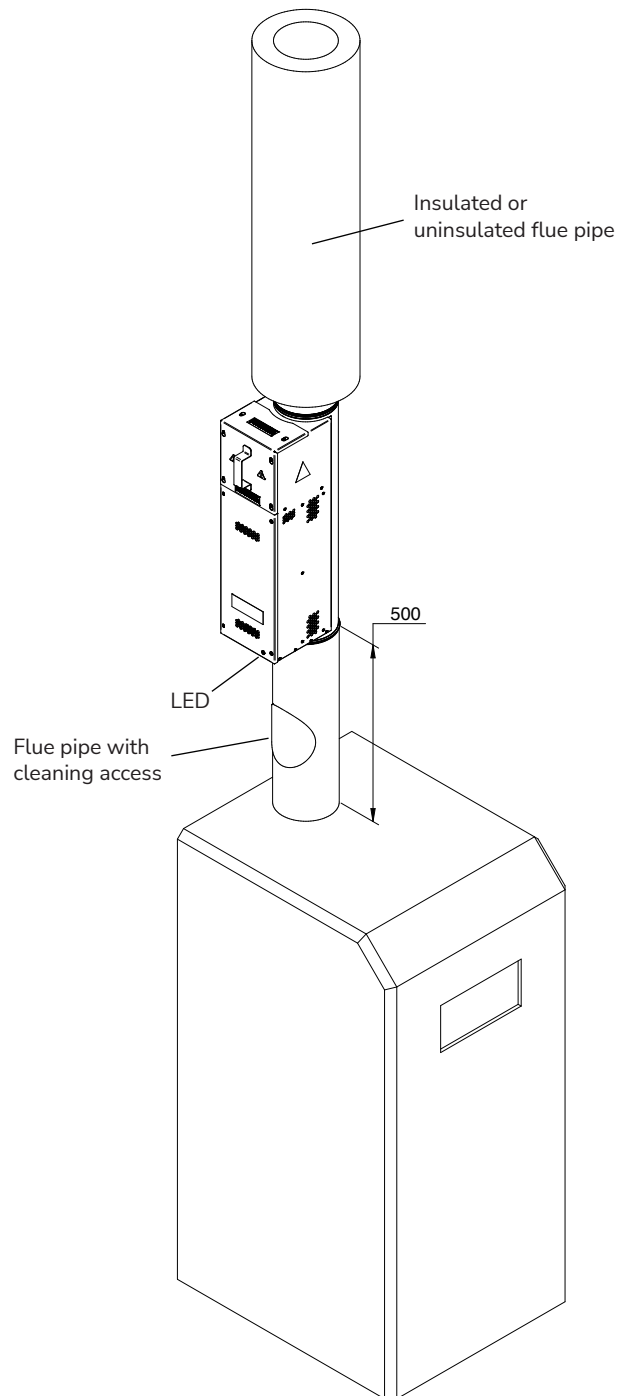

Installation on boiler with upward flue outlet



## Attach the warning signs



The chimney sweeper must be made aware that the chimney is fitted with an ESP-25 filter. The included high voltage warning signs must be placed on all inspection/cleaning hatches in the chimney system.

## Connect the ESP-25 to power

Connect the ESP-25 power cable to the electrical socket or directly to the boiler. See the section ***Electrical installation***.

# Controller

The illustration and table below shows an overview of the inputs and outputs of the controller.

Controller input/output	A	B	C	D	E	F
	Supply 1 x 230 V	Not used	Not used	LED diode	Not used	Not used

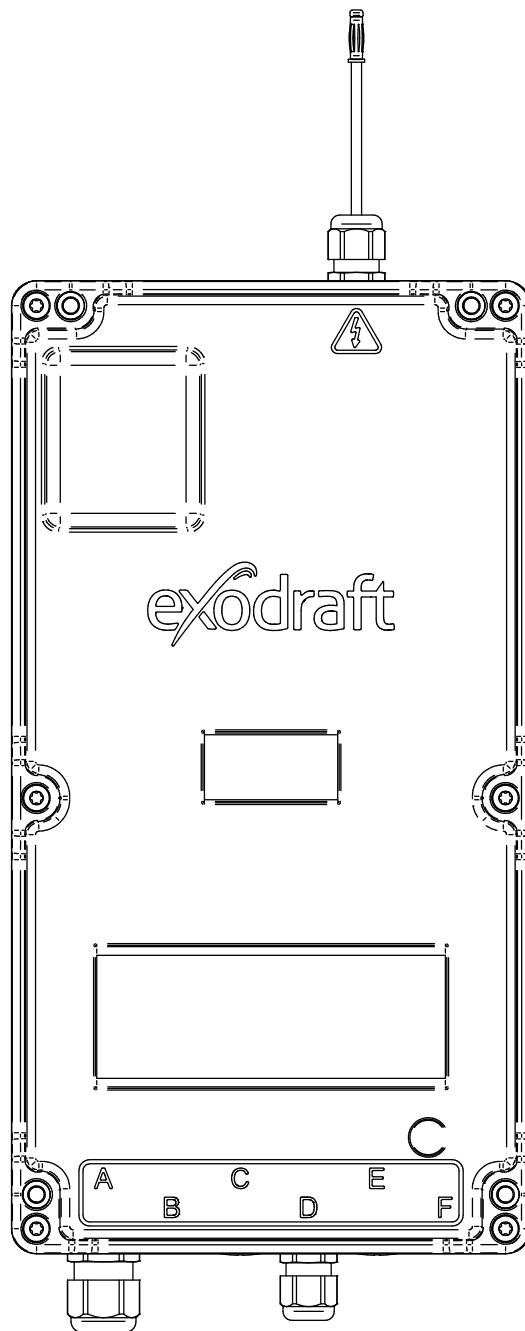

# Electrical installation

The electrical installation should only be carried out by qualified personnel in compliance with applicable laws.



**ATTENTION!** Always disconnect the power supply before working on ESP-25 and make sure that it cannot be reconnected accidentally. Always check that the installed isolation switch is set to off and/or the pellet boiler is turned off.

## General information

- The electrical installation must be carried out in compliance with applicable laws.
- The ESP-25 **must have (PE) ground connection**. Power supply needed: 230 V AC / 1.0 A.

## Power connection

The ESP-25 is delivered with stripped conductors. A plug with (PE) ground connection needs to be installed on the ESP-25. The plug must match the local requirements for electrical installations.

Exodraft recommend that a 2 pole isolation switch, is to be fitted to the cable.

**To avoid unnecessary power consumption, remember to turn off the ESP-25 when the pellet boiler is off.**

## Power connection by automatic on/off - option 1

ESP-25 can be connected to the pellet boilers main board and be configured to start and stop with the pellet boiler if it has an available 230 V output. The 5 metre long cable with stripped conductors must then be routed to the pellet boilers outlet according to the electrical diagram.

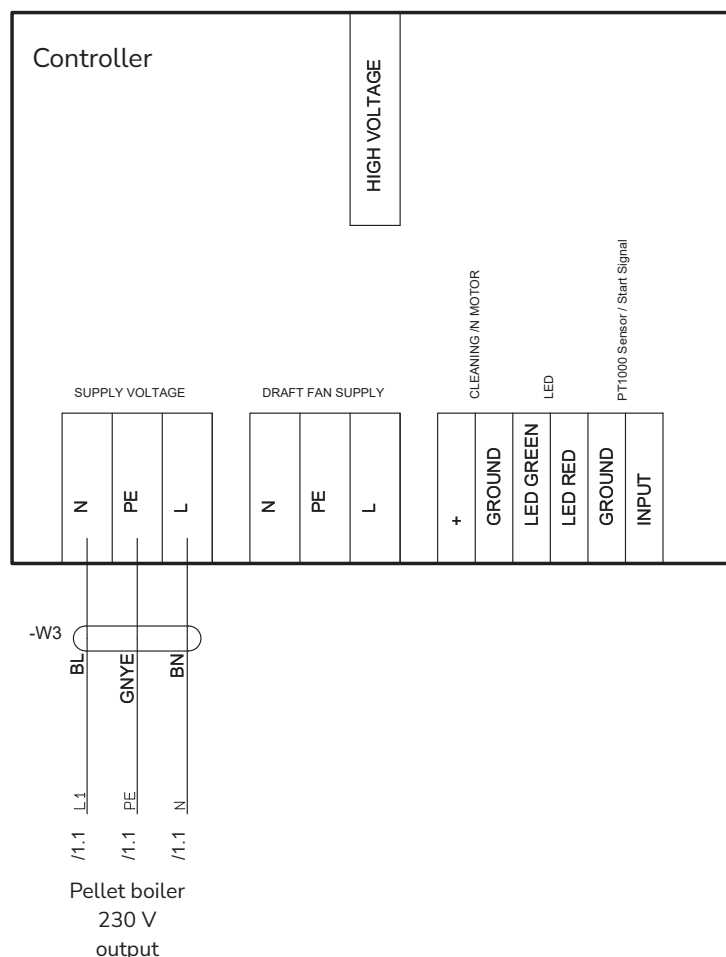

## Power connection by automatic on/off - option 2



**ATTENTION!** This type of installation should only be carried out by a qualified electrician. Any possible damage to the controller/mainboard after opening is not covered by the warranty.

ESP-25 can be connected to the boiler through a relay setup (control box start / stop). In this way, ESP-25 can be connected to all available 24-230V outputs on the pellet boiler.

- Prepare a control box to contain the relay system. E.g. use a suitable plastic enclosure and use cables glands for strain relief of cables.
- Connect the 5 metre long supply cable from the ESP-25 to an external power supply cable. Make the connection with terminal strip/block inside the Control Box.
- Connect a 2-wire cable from one of the pellet boiler's 24-230V outputs to a 24-230V relay.
- Replace the M12 blind plug mounted in the Controllers output F with a M12 cable gland. Replace the M12 blind plug mounted at the bottom of the ESP-25 with a M12 cable gland.
- Connect a 2-wire cable from the 24-230V relay to the controllers 6-pole terminal block. Route the cable through the cable glands.
- Move the jumper on the controllers mainboard.

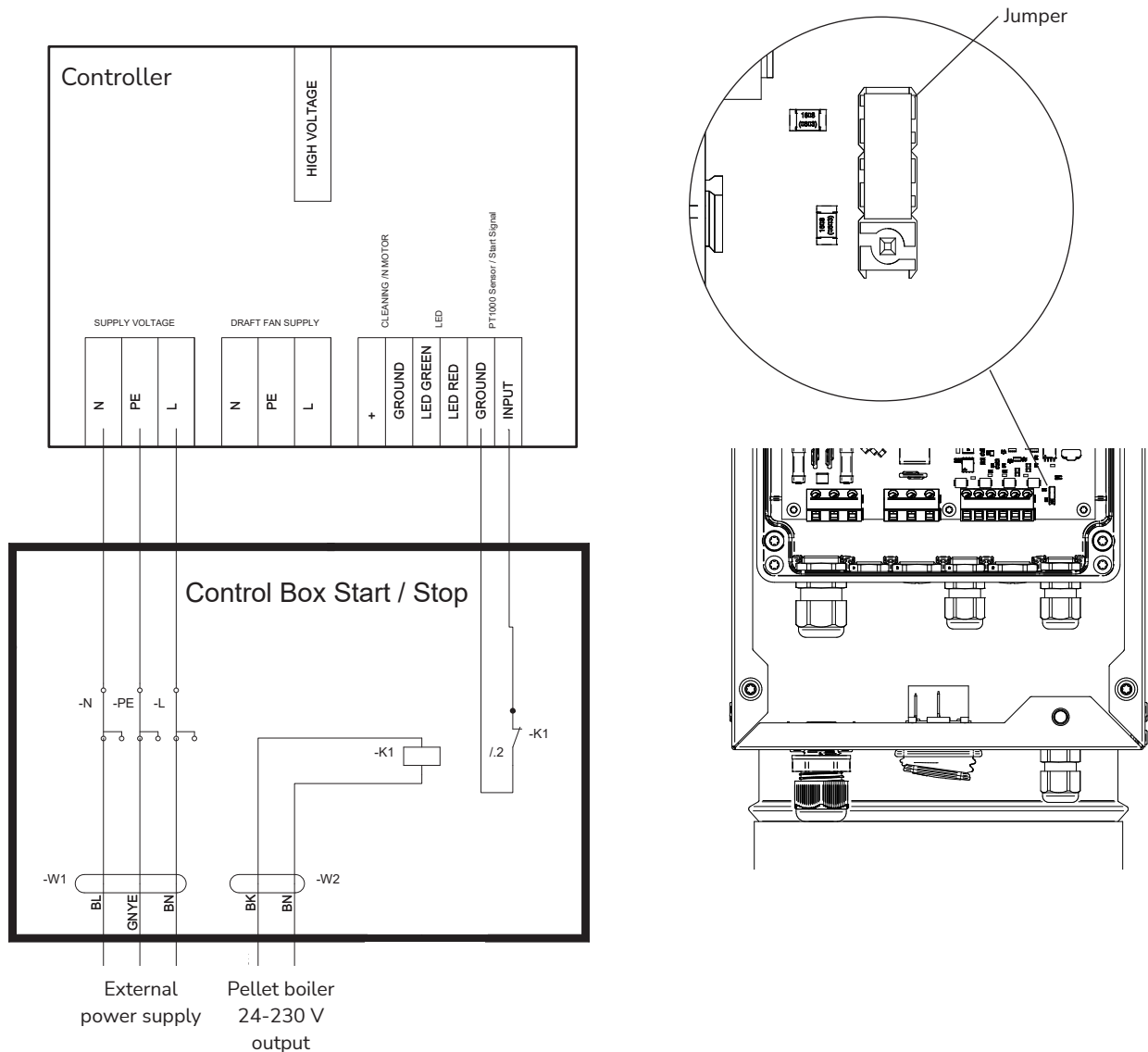

# Start-up and configuration

## General

To enable the user to switch on the ESP-25, it must be electrically installed as described under **Electrical installation**. After the installation, turn on the main switch on the ESP-25. If installed directly to an electrical socket, the ESP-25 will start up immediately. If installed with automatic start/stop the ESP-25 will start up when the pellet boiler is started.

No additional configuration needs to be performed. The ESP-25 runs automatically.

## System test

When the ESP-25 is activated for the first time, the chimney must be cold. Check that the LED lights up green after approx. 10 seconds. There may be a very slight buzzing sound when the filter starts, this is normal. However, there must be no constant flashover voltage. See NOTE!

Once these points have been checked, the filter is ready for use.



**NOTE!** On some pellet boiler systems, you may hear individual flashover voltages as small bangs during operation. This is normal and will settle after the ESP-25 has been in operation for a while.

# User operation instructions

## User operation

Always use pellets of an approved quality that are dry and make sure you always follow the pellet boiler's manual. **DO NOT USE THE PELLETT BOILER WHEN THE ESP-25 IS OFF OR THE POWER SUPPLY IS NOT CONNECTED.**

For the ESP-25 to work correctly, it must be connected to a grounded 230V electrical socket and electrically installed as instructed in this manual.

When the ESP-25 is switched on, the LED will flash green during start up and remain green when the ESP-25 is ready. It is recommended that the LED is always visible from the pellet boiler's operating side.

The efficiency of the ESP-25 can only be guaranteed if the boiler is properly adjusted for optimal combustion.

The efficiency and general functionality of the ESP-25 cannot be guaranteed if installed on pellet boilers with a heating output higher than 25 kW. The build-up of particles will occur much faster, which causes a faster decrease in efficiency, and very frequent cleaning will be required.



**NOTE!** Be aware that even if the ESP-25 fails, the pellet boiler may still be in operation. In the event of a power failure (and the ESP-25 is not supplied with power), air and smoke will be able to pass freely through the flue, meaning that the pellet boiler is still safe to use.



**CAUTION!** Do not overheat the pellet boiler. Small deposits of soot can ignite and start a chimney fire, which can cause dangerously high temperatures in the chimney. If you have been exposed to a chimney fire, then you must ensure that the mechanical and electrical functions of the ESP-25 are inspected. If errors or irregularities are found, then these must be rectified before using the ESP-25 or pellet boiler further.

## Indications on the ESP-25

The LED is located at the lower lid of the ESP-25 and indicates the current status.

The following diagram illustrates the various status categories, as indicated by the LED.

---

<b>LED</b>		
No light - OFF	●	OFF
Green - ON	●	In operation
Red - ON	●	General failure
Flashing Red once per second	● ● ● ●	No PE connection
Flashing Red/Green once per second	● ● ● ●	Current limiter/sparkover safety system activated
Solid green for 2 seconds, flashing red once per second	● ● ● ● ●	The ESP-25 controller is overheated

---

# Maintenance and troubleshooting

## Safety precautions

The ESP-25 must be cleaned at regular intervals and can be performed by the user. The cleaning intervals may vary depending on the type of pellet boiler, and whether the pellet boiler is properly adjusted for optimal combustion. Pellet boilers with a heat output of up to around 25 kW can expect more frequent cleaning than pellet boilers with a lower heat output. However, the ESP-25 must be cleaned at least after every 1000 kg of pellets burned.

Furthermore, the ESP-25 must be inspected and serviced at least once a year. Soot and other deposits must be removed from the insulator compartment and the insulator. Inspection and service can also be carried out by the user, however inspection of the chimney must be carried out by a qualified person, for example, a chimney sweeper.

---

**Before working on the ESP-25 and during maintenance, the ESP-25 must be switched off.**

**Please note that in all situations the plug must be removed from the electrical socket before beginning maintenance. If the ESP-25 is connected to 24-230V output on the boiler, then the ESP-25's power switch must be switched off, and the pellet boiler must be switched off!**

**Furthermore, allow the ESP-25 and chimney system to cool down before servicing or cleaning, as the external surface may become hot during operation. Ensure that the pellet boiler and the ESP-25 cannot be turned on accidentally.**

**Do not open any part of the ESP-25 filter unless the power supply is turned off via the power switch and the plug has been removed from the electrical socket.**

**When the pellet boiler is started, the high voltage can be automatically activated if automatic start/stop installation is used. Touching the electrode or any internal part of the ESP-25 during operation can be fatal.**

**The user or chimney sweeper should inspect the ESP-25 after the first month of use to identify excessive particle build-up.**

---



## User maintenance

- The user must service the ESP-25 at least once yearly.
- The user must be aware of the status of the ESP-25 and react if something unusual should happen.
- The user must respond to abnormal noise or other abnormal operation.
- The user must inspect the ESP-25 in case of abnormal operation.
- The user must seek certified assistance if it is not possible for them to resolve the error on their own.
- The user is responsible for hiring a chimney sweeper to clean the chimney and perform regular checks on the chimney construction to ensure that flue gas can pass freely through the ESP-25 flue.



**NOTE!** The ESP-25 can be inspected/cleaned by the user according to the manual.



**NOTE!** When cleaning, it must be ensured that there is free passage for any water through all drainage points. The manufacturer cannot be held responsible for ingress of water of any kind.



**NOTE!** As a user, do not open the controller. Any possible damage to the controller/mainboard after opening is not covered by the warranty.



**NOTE!** It is the user's responsibility to inform the chimney sweeper that an ESP-25 has been installed, so that the chimney sweeper is aware of this before cleaning the chimney. If the chimney sweeper is to clean from the boiler room (cleaning the chimney from below and below the ESP-25), the user must introduce the chimney sweeper to the procedure in the manual. Alternatively, the user can prepare the ESP-25 for chimney cleaning before the chimney sweeper visits.

## Inspection and service



**DANGER!** Make sure that the ESP-25 is switched off, unplugged from the socket and that the pellet boiler is turned off during cleaning, inspection and servicing.

During inspection and service remove the lids for access to the insulator and technical compartments and check the following.

### Access to the insulator and technical compartments:

Loosen all screws from the upper lid, remove all screws from the lower lid, and remove the lids.

- 10 screws (tool – TX20)

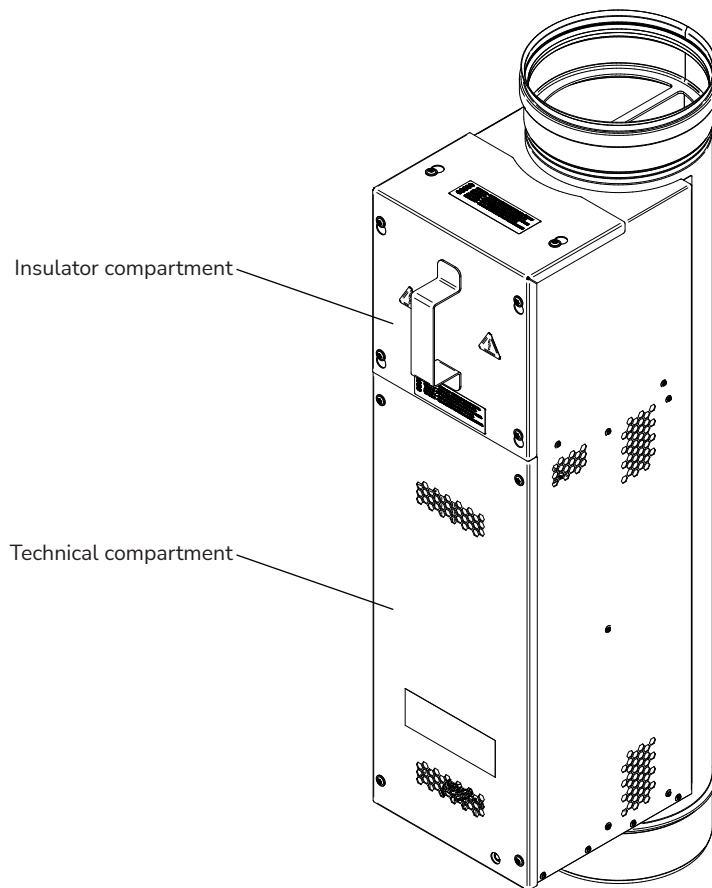

**General internal condition, insulator compartment:**

- Check the type of soot in the flue. If black and tar-like soot deposits form on the internal surfaces of the flue and insulator compartment, the combustion is not correct and this should be checked. Consult with your chimney sweeper.
- Check general cleanliness and surfaces in the insulator compartment and clean any accumulation of soot.
- Check the condition of the insulator. It must not have visible damage or signs of deformation. Clean the insulator and any soot deposits.
- Check the condition of the electrode. It must be removed and checked for corrosion or other pitting.
- Check the condition of the silicone gasket. It must not have leaks or other damage and must not be loose.

In case of defects, please contact your Exodraft dealer.

**General internal condition, technical compartment:**

- Check general cleanliness.
- Check the two ground tab connectors and the ground connection. They must not be loose.
- Check the supply cables' connection.

In case of defects, please contact your Exodraft dealer.

**General external condition and inspection of the chimney (consult with your chimney sweeper):**

- Is the ESP-25 properly installed in the chimney construction?
- Are all lids properly secured?
- Are external components such as rivets and handles fastened correctly?
- Are there free passage for flue gas through the ESP-25 flue?

**Cleaning and service of the insulator**

- The insulator is cleaned with a piece of cloth using brake cleaner or similar. Cleaning needs to be done all the way around the insulator.

**Replacing spare parts**

Apart from replacing the electrode in case of damage, no other repairs to the ESP-25 are allowed by user without first seeking advise. In case of defects, please contact your Exodraft dealer.

## Cleaning procedure - performed by user

### Cleaning by user

Step	Action
1	The boiler must be switched off. Wait for the chimney to cool down.
2	The main switch of the ESP-25 must be switched off, and the supply cable must be unplugged from the electrical socket (if not powered by the boiler).
3	Loosen the 6 screws from the upper lid and remove the lid. (Tool - TX20).
4	Use an ash/soot vacuum cleaner to clean around the insulator.
5	Carefully use the included flexible cleaning brush to clean the flue pipe on both sides of the electrode.
6	Ensure that the electrode is still aligned in the flue pipe after cleaning.
7	Remove desopites of dust/particles from the soot cap or through the cleaning door if installed as recommended.

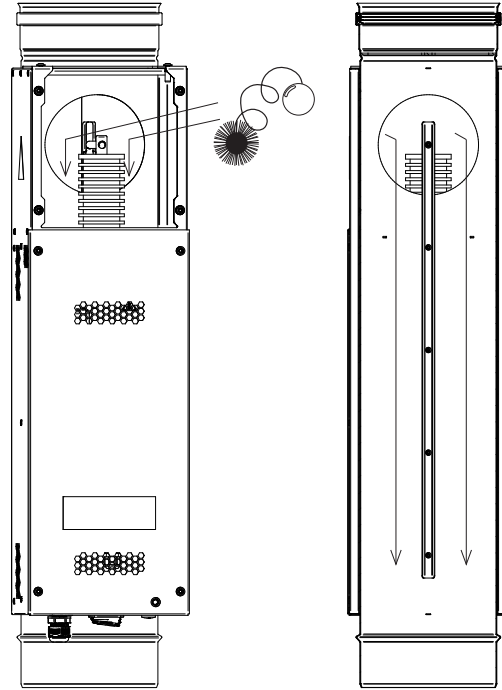

### Removal and cleaning of the electrode (optional)

Step	Action
1	The boiler must be switched off. Wait for the chimney to cool down.
2	The main switch of the ESP-25 must be switched off, and the supply cable must be unplugged from the electrical socket (if not powered by the boiler).
3	Loosen the 6 screws from the upper lid and remove the lid. (Tool - TX20).
4	Loosen the set screw (Tool - internal 3mm Allen key) until it flushes with the top of the steel pin.
5	Pull the electrode towards the flue pipe. Be careful not to drop the electrode into the flue pipe! Then pull it out of the flue pipe.
6	Clean the electrode by vacuuming or with a brush.
7	After cleaning insert the electrode and fasten the set screw. Ensure that the electrode is aligned in the flue pipe.

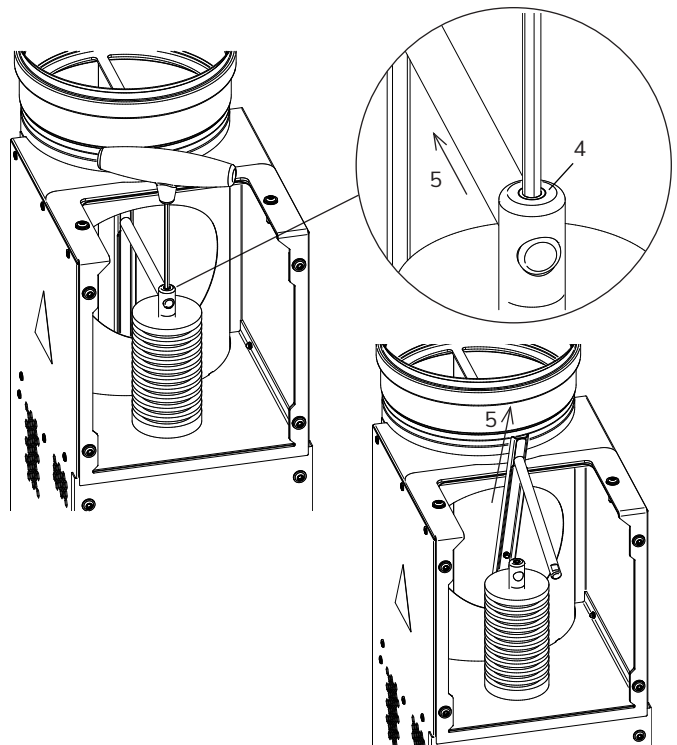

## Chimney sweeping - performed by chimney sweeper

Step	Action
1	The boiler must be switched off. Wait for the chimney to cool down.
2	The main switch of the ESP-25 must be switched off, and the supply cable must be unplugged from the electrical socket (if not powered by the boiler).
3	Loosen the 6 screws from the upper lid and remove the lid. (Tool - TX20).
4	Loosen the set screw (Tool - internal 3mm Allen key) until it flushes with the top of the steel pin.
5	Pull the electrode towards the flue pipe. Be careful not to drop the electrode into the flue pipe! Then pull it out of the flue pipe.
6	Chimney sweeping can be performed.
7	After chimney sweeping insert the electrode and fasten the set screw. Ensure that the electrode is aligned in the flue pipe.

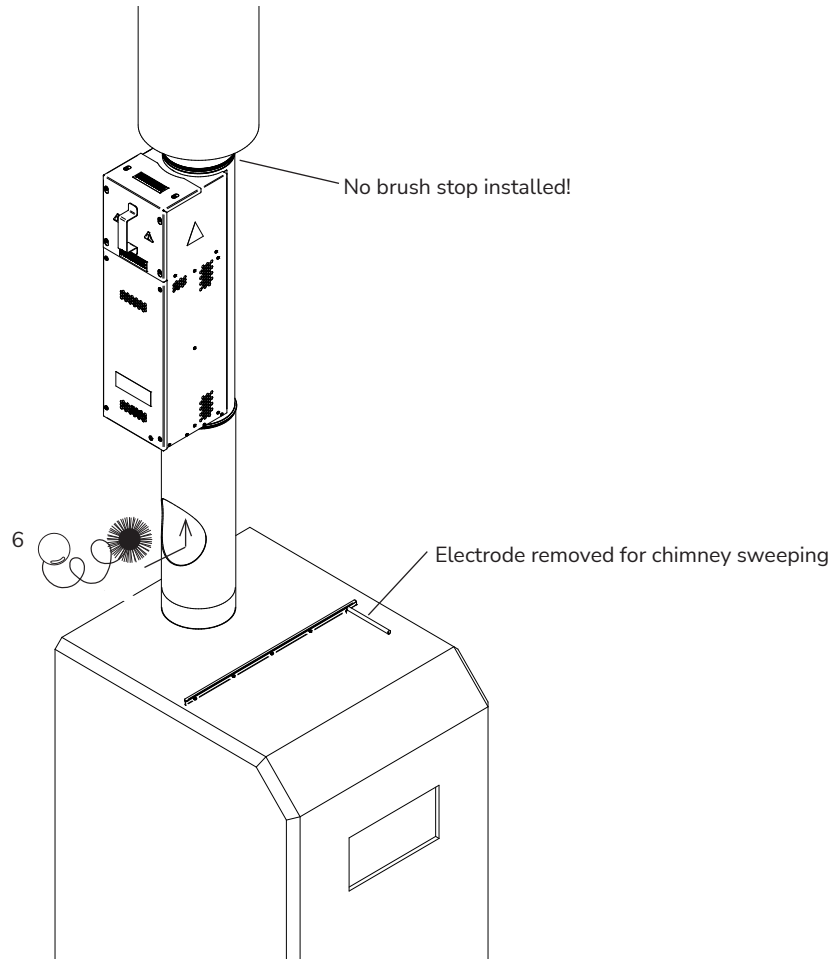
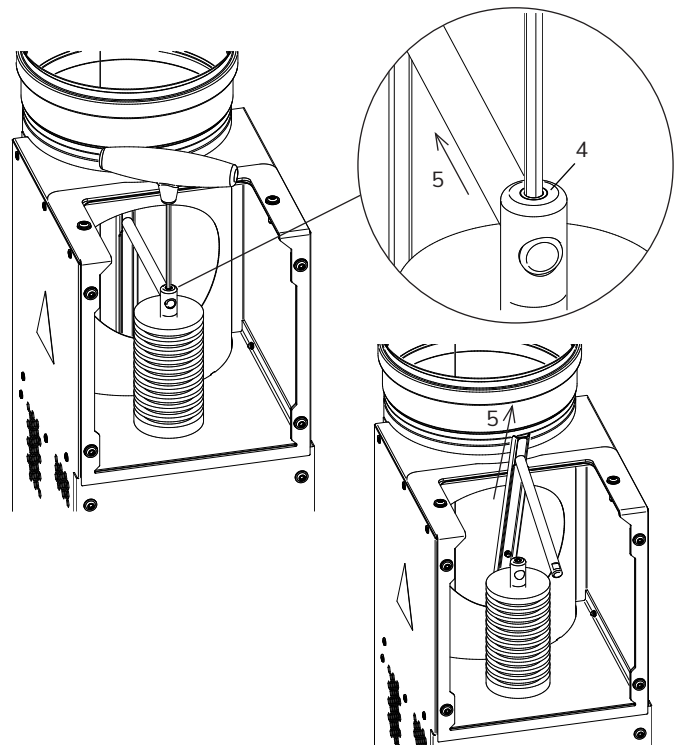

## Troubleshooting

Troubleshooting when warning lights are on. Please refer to section *Indications on the ESP-25*.

Observation	Problem	Solution
LED constant red	General failure	Call for service
Flashing red LED	Poor or no PE connection	Connect the power supply to a grounded power outlet
Red/green light flashing once a second for 10 minutes	Current limiter/sparkover safety system activated	Check the alignment of the electrode
Red/green light flashing 5 times per second	Current limiter/short circuit safety system activated	Check the alignment of the electrode and inspect the electrode for defects

## Other problems and solutions

Observation	Problem	Solution
No power supply to the ESP-25	The power is off	Check the power supply Check the main switch on filter
The power supply to the filter is on but it is not working	Poor or no PE connection	Have certified personnel establish grounded connection
Noises are coming from the ESP-25	There might be "spark overs" Foreign objects may be stuck inside	This is normal for short periods. If ongoing check electrode alignment Remove foreign objects



**UK Conformity Assessed**

---

**exodraft**

**Exodraft a/s  
Industrivej 10  
DK-5550 Langeskov**

---

Hereby declares that the following products:

---

ESP-25

---

Were manufactured in conformity with the provisions of the following regulations:

---

**The Supply of Machinery (Safety) Regulations 2008**

**Electrical Equipment (Safety) Regulations 2016**

**Electromagnetic Compatibility Regulations 2016**

---

Langeskov, 01-11-2022  
Managing Director  
*Anders Haugaard*

---



## Declaration of Conformity

DK: EU-Overensstemmelseserklæring  
GB: Declaration of Conformity  
DE: EU-Konformitätserklärung  
FR: Déclaration de conformité de l'Union Européenne  
NO: EU-Samsvarserklæring  
PL: EU Deklaracja zgodności

NL: EU-Conformiteits verklaring  
SE: EU-Överensstämmelsedeklaration  
FI: EU-Vaatimustenmukaisuusvakuutus  
IS: ESS-Samræmisstaðfesting  
IT: Dichiarazione di Conformità Unione Europea

**exodraft**

**Exodraft a/s  
Industrivej 10  
DK-5550 Langeskov**

Erklærer på eget ansvar, at følgende produkter:  
Hereby declares that the following products:  
Erklært hierdurch auf eigene Verantwortung, daß folgende Produkte:  
Déclare, sous sa propre responsabilité, que les produits suivants:  
Erklærer på eget ansvar at følgende produkter:  
Niniejszym oświadczam, że następujące produkty:

Veklaart dat onderstaande producten:  
Deklarerar på eget ansvar, att följande produkter:  
Vastaa siltä, että seuraava tuote:  
Staðfesti à eigin àbyrgð, að eftirfarandi vörur:  
Dichiara con la presente che i seguenti prodotti:

ESP-25

Som er omfattet af denne erklæring, er i overensstemmelse med følgende standarder:  
Were manufactured in conformity with the provisions of the following standards:  
Die von dieser Erklärung umfaßt sind, den folgenden Normen:  
Auxquels s'applique cette déclaration sont en conformité avec les normes ci-contre:  
Som er omfattet av denne erklæring, er i samsvar med følgende standarder:  
Zostały wyprodukowane zgodnie z warunkami określonymi w następujących normach:

Zijn vervaardigd in overeenstemming met de voorschriften uit de hieronder genoemde normen en standaards:  
Som omfattas av denna deklaration, överensstämmer med följande standarder:  
Jota tämä selvitys koskee, on seuraavien standardien mukainen:  
Sem eru meðtalin í staðfestingu Pessari, eru í fullu samræmi við eftirtalda staðla:  
Sono stati fabbricati in conformità con le norme degli standard seguenti:

### EN 60335-1, EN 60335-2-80, DS/EN ISO 12100: 2011

I.h.t bestemmelser i direktiv:  
In accordance with  
Entsprechen gemäß den Bestimmungen der folgenden Richtlinien:  
Suivant les dispositions prévues aux directives:  
I.h.t bestemmelser i direktiv:  
Zgodnie z:

En voldoen aan de volgende richtlijnen:  
Enligt bestämmelserna i följande direktiv:  
Seuraavien direktiivien määräysten mukaan:  
Med tilvisun til ákvarðana eftirlits:  
In conformità con le direttive:

Maskindirektivet:  
The Machinery Directive:  
Richtlinie Maschinen:  
Directive Machines:  
Maskindirektivet:  
Dyrektywę maszynową:

De machinerichtlijn:  
Maskindirektivet  
Konedirektiivi:  
Vèlaeftirlitið:  
Direttiva Macchinari:

### 2006/42/EF-EEC/-EWG/-CEE

Lavspændingsdirektiv:  
The Low Voltage Directive:  
Niederspannungsrichtlinie:  
Directive Basse Tension:  
Lavspenningsdirektivet:  
Dyrektywę Niskonapięciową

De laagspanningsrichtlijn:  
Lågspänningsdirektivet:  
Pienjännitedirektiivi:  
Smáspennueftirlitið:  
Direttiva Basso Voltaggio:

### 2014/35/EC

EMC-direktivet:  
And the EMC Directive:  
EMV-Richtlinie:  
Directive Compatibilité Electromagnétique:  
EMC-direktivet:  
Dyrektywę EMC – kompatybilności elektromagnetycznej

En de EMC richtlijn:  
EMC-direktivet:  
EMC-direktiivi:  
EMC-efirlitið:  
Direttiva Compatibilità Elettromagnetica:

### 2014/30/EC

**Langeskov, 01-11-2022**  
Adm. direktør  
Managing Director  
Anders Haugaard

Algemeen directeur  
Geschäftsführender Direktor  
Président Directeur Général  
Verkställande direktör  
Toimitusjohtaja  
Frankvemdastjóri  
Direttore Generale









## **DK: Exodraft a/s**

Industrivej 10  
DK-5550 Langeskov  
Tel: +45 7010 2234  
Fax: +45 7010 2235  
info@exodraft.dk  
www.exodraft.dk

## **SE: Exodraft a/s**

Kalendevägen 2  
SE-302 39 Halmstad  
Tel: +46 (0)8-5000 1520  
info@exodraft.se  
www.exodraft.se

## **NO: Exodraft a/s**

Storgaten 88  
NO-3060 Svelvik  
Tel: +47 3329 7062  
info@exodraft.no  
www.exodraft.no

## **UK: Exodraft Ltd.**

24 Janes Meadow, Tarleton  
GB-Preston PR4 6ND  
Tel: +44 (0)1494 465 166  
Fax: +44 (0)1494 465 163  
info@exodraft.co.uk  
www.exodraft.co.uk

## **DE: Exodraft a/s**

Niederlassung Deutschland  
Industriestraße 14  
DE-55768 Hoppstädten-Weiersbach  
Tel: +49 6782 989 590  
Fax: +49 6782 989 5929  
info@exodraft.de  
www.exodraft.de

## **FR: Exodraft sas**

78, rue Paul Jozon  
FR-77300 Fontainebleau  
Tel: +33 (0)6 3852 3860  
info@exodraft.fr  
www.exodraft.fr

Your energy. Optimized.

The logo for Exodraft, featuring the word "exodraft" in a bold, lowercase sans-serif font. The letter "x" is stylized with a curved line that loops around the top and bottom of the letter, suggesting motion or energy.