

Control

EFC21

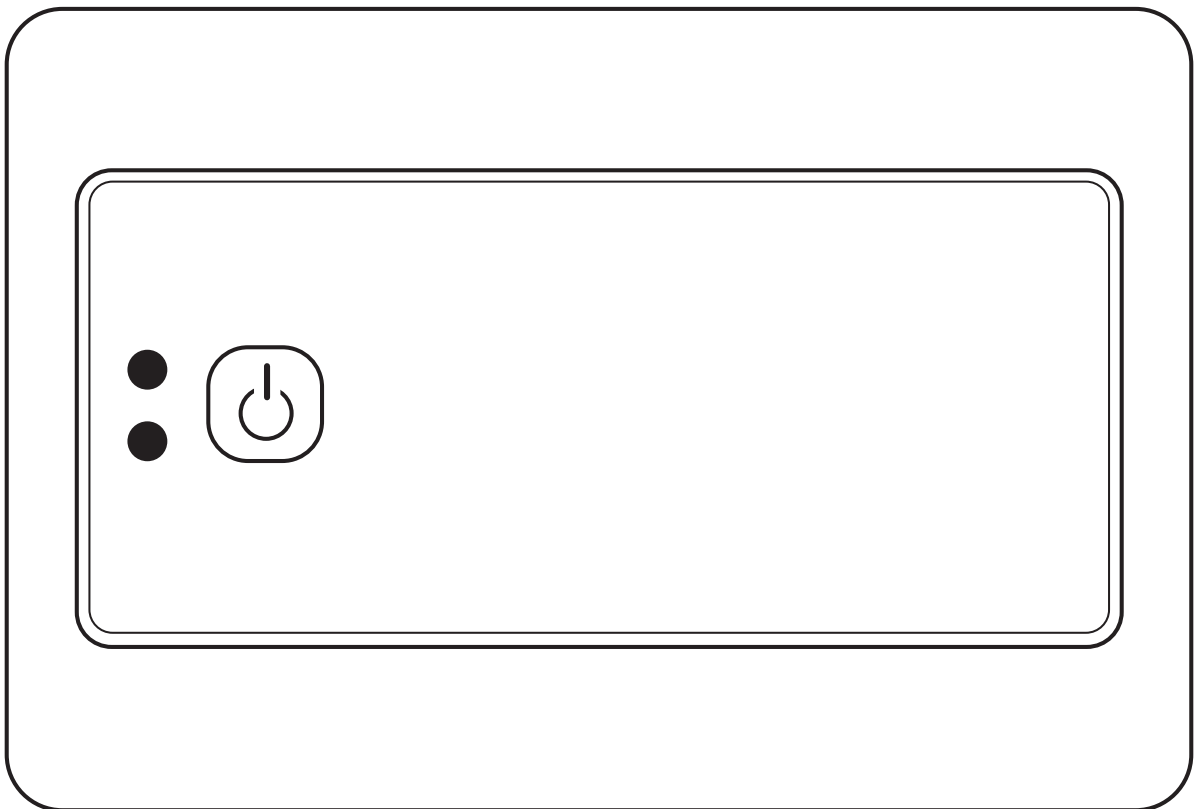

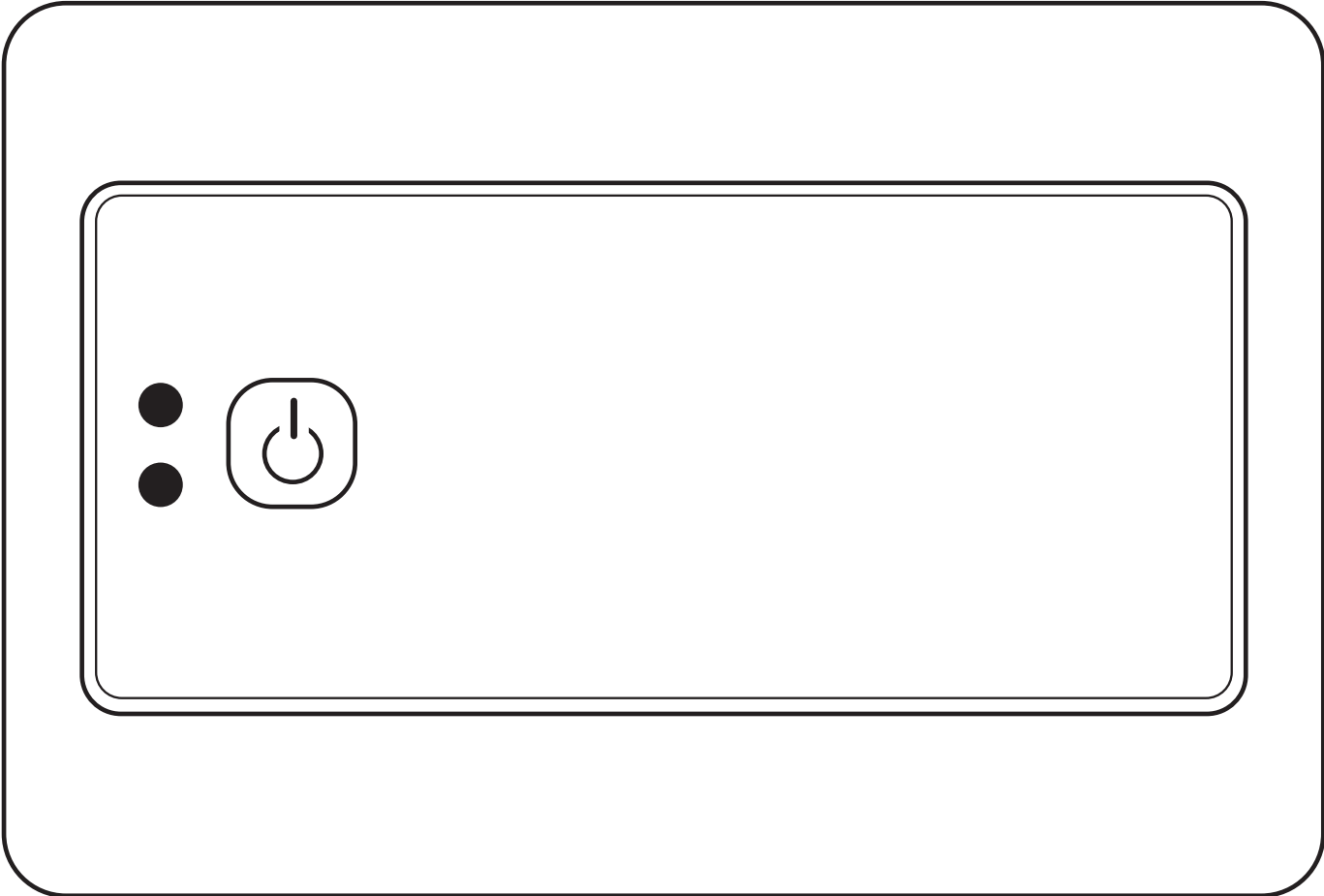

Control | EFC21

Content

Product information	7
Scope of supply	7
Spare parts	7
Warranty	8
Technical specifications	9
Construction and components	10
Installation	11
Fitting the controller	11
Electrical wiring	11
Standard installation	12
Installation with external ON/OFF	13
EFC21 coupled directly to a gas fireplace control	14
Commissioning	15
Service mode	15
Setting the potentiometer	16
Setting the pressure switch	16
Testing the commissioning set-up	16
Daily use	17
Extra function	17
Troubleshooting	18
Start	18
Operating	18
Approvals	19
UK Conformity Assessed	20
Declaration of Conformity	21



How to use this manual

This manual has been prepared based on the specific product and contains relevant technical information and installations guides.

Accessories and spare parts are not covered by this manual. Please refer to the individual manuals of these components.

This installation manual does not contain any system design documentation.

Failure to observe instructions marked with a danger symbol may result in personal injury and/or damage to the product.

Errors and omissions excepted.



Disposal

Electrical and electronic equipment (EEE) often contain materials, components and substances that may harm the environment or be hazardous to your health. Products (WEEE) marked with the 'crossed-out wheeled bin' symbol should be disposed of separately from other waste at the end of its life. Though legislation may differ from country to country we strongly advise that electrical and electronic waste is separated from other waste and disposed of according to national legislation to protect the environment and personnel that may come into contact with waste.

Symbols

The following symbols may be used in the manual to draw attention to danger or risk of personal injury or damage to the product.



General prohibition

Failure to observe instructions marked with the prohibited symbol may result in extreme danger or serious personal injury.



General attention

Marks a dangerous situation that, in the worst-case scenario, can cause serious personal injury or significant damage to the product.



General warning

Failure to observe instructions marked with a danger symbol may result in personal injury and/or damage to the product.



Electricity hazard/High Voltage

Marks a situation in which caution is advised due to the risk of high voltage electric shock which can cause serious personal injury or significant damage to the product.



Connect an earth terminal to the ground

Failure to observe instructions marked with a danger symbol may result in personal injury and/or damage to the product.



Permitted and approved

Permitted and approved method of installation.



Prohibited and not approved

Prohibited and not approved method of installation.



Warning

To minimise the risk of fire, electric shock, personal injury and/or damage to the product please observe the following:

- Please always read the manual and only use the product in accordance with the manufacturer's instructions. If in doubt, contact one of the Exodraft specialized dealers.
- All installations must be carried out by properly qualified personnel in accordance with national legislation and regulations.
- This product must be earthed. Get assistance from an qualified electrician when in doubt.
- This product must always be disconnected under the installation.
- Prior to servicing the product, disconnect the power and ensure that it cannot accidentally be reconnected.
- Exodraft always recommends the use of a smoke alarm when a solid fuel open fire is installed.
- If the Exodraft fan system has been designed for solid fuel/multi fuel installations, please ensure that the design meets the requirements of BS EN15287-1. If this cannot be achieved, a smoke alarm must be installed in the same room as the heat appliance.

Product information

EFC21 is used to control gas fireplaces that have Exodraft chimney fans installed.

The control system functions as a safety monitoring system and will switch off the gas fireplace if there is insufficient chimney draught.

The system has been developed in accordance with standards BS 5440-1: 2008, BS 6644 :2005+A1:2008, Appliances Burning Gaseous Fuels Directive 2016/426/EC and EN298 (2012).

Incorrect use may result in problems with soot, chimney fires, etc. which might damage the product. Please check out this site for advice about the product:

www.exodraft.com

Scope of supply

- EFC21
- Temperature sensor
- Installation manual and user instructions

Spare parts

The table below shows the spare parts available for the EFC21-model.

Spare parts*
Temperature sensor

*This manual does not describe the specific use of spare parts. We refer to the separate manuals for such components. For more details contact your Exodraft dealer.

Warranty

All Exodraft products are covered by a 2-year guarantee as per European consumer rights legislation. For some countries an extended period of guarantee may apply depending on either national legislation or other clearly stipulated conditions. Customer complaints must be handled by a specialised dealer or wholesaler (preferably where the Exodraft product has been bought originally). An updated list of Exodraft specialised dealers can be found on our website for the country in question.

Exodraft products must always be installed by properly qualified personnel. Exodraft reserves the right to change these guidelines without prior notice.

The warranty and liability does not cover instances regarding personal injury or damage to property or the product that can be ascribed to one or more of the following causes:

- Failure to follow this installation and operation manual
- Incorrect installation, start-up, maintenance or servicing
- Improper repairs
- Unauthorised structural modifications made to the product
- Installation of additional components that have not been tested/approved with the product
- Any damage resulting from continued use of the product despite an evident defect
- Failure to use original spareparts and accessories
- Failure to use the product as intended
- Exceeding or failure to meet the limit values in the technical data
- Force majeure

Technical specifications

The fan will start at full speed when the EFC21 is activated. Once the system detects there is sufficient chimney draught, the gas fireplace can be lit and the fan speed will fall to the pre-set level.

The control has a step-up function and a built-in 15 second delay to avoid inadvertent cut-outs. If the control system is switched off the chimney fan will stop.

But an optional three-minute run on can be set by the DIP switch.

Technical data

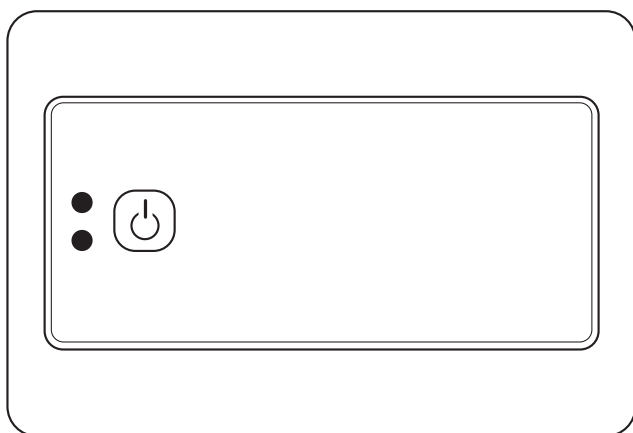

Description	EFC21
H x W x D [mm]	85 x 126 x 32
Supply voltage	230 V ±10%/50 Hz
Fuses:	T 3,15 A
Release out	Max. 3,15 A 250 VAC/3,15 A 30 VDC
EFC21 SMG out	230 VAC, max. 100 VA
Chimney fan out	Max. 1.8 A/230 V (AC3)
Air inlet (Damper)	24 VDC (closed-circuit supply)
External start	24 VDC (closed-circuit supply)
Ingress Protection	IP 30
Material	ABS plastic
Ambient temperature:	-10 °C to + 40 °C

Construction and components

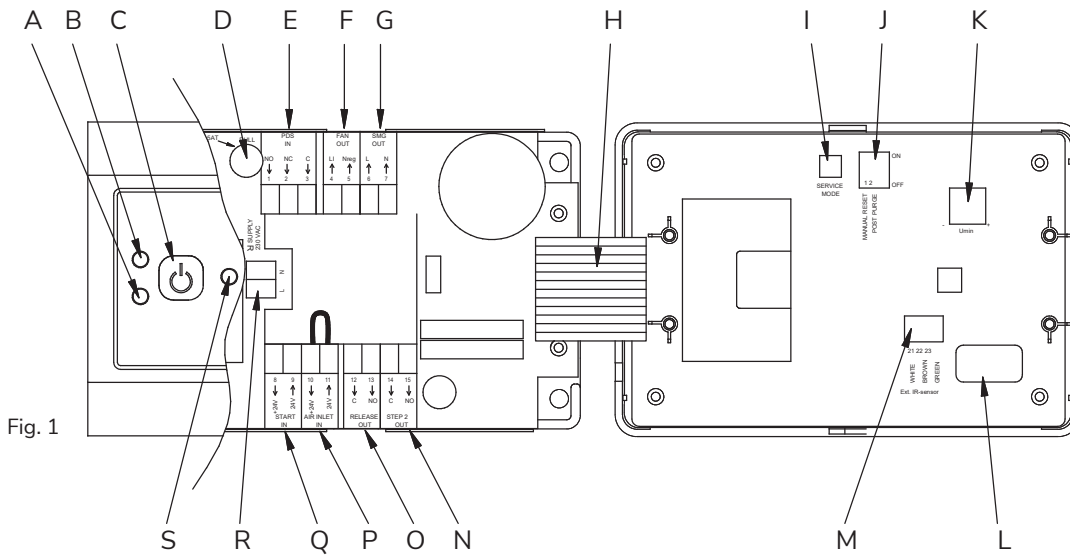

Fig. 1

A	Alarm LED	K	Potentiometer for adjusting the fan speed
B	Operating LED	L	Product ID
C	ON/OFF button	M	n/a
D	Fuse T 3,15 A 230 V (spare fuse is also included)	N	n/a
E	Pressure switch terminal	O	Gas fireplace start terminal
F	Fan terminal	P	Air inlet monitoring terminal
G	SMG solenoid valve)	Q	External ON/OFF terminal
H	Connection cable	R	Power supply terminal
I	Service mode button	S	n/a
J	DIP switch		

Installation

Fitting the controller

The control panel must be fitted onto a level surface with a minimum distance of 100 mm to any corner.

The front cover is removed from the frame by twisting a screwdriver in the two holes on the sides of the cover. The front cover can then be tipped carefully and the frame can be fitted onto the wall.

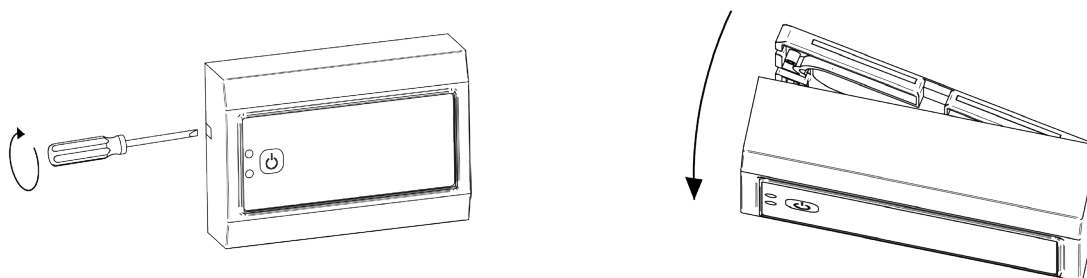

The front cover is fitted with connection cable on the right side which limits how much this side can be opened.

The controller covers a standard dry lining box (80 x 80 mm).

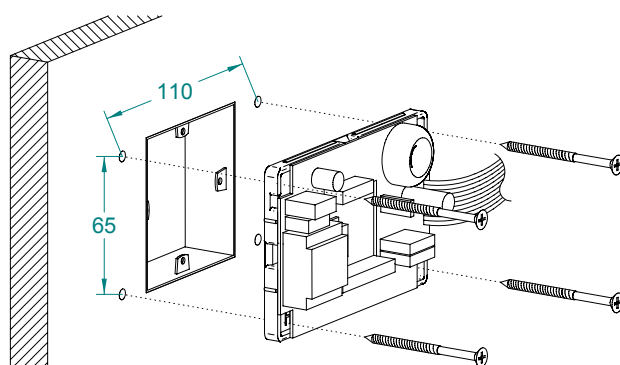

Fig. 3

Electrical wiring



Electrical wiring of the controller must be carried out in accordance with national legislation and regulations. Earth must always be connected.

Standard installation

The diagram shows how a separate solenoid valve (SMG) must be connected to the EFC21. The solenoid valve is part of the separate fail-safe system and will cut off the gas supply in the case of insufficient system chimney draught (controlled by the fan pressure switch).

- Connect the earths of the mains supply, chimney fan and solenoid valve together (SMG).
- Connect the chimney fan and pressure switch to terminals 1–5.
- Connect the SMG to terminals 6–7.
- Connect the optional Air inlet monitoring to terminals 10–11.
If this monitoring is not mandatory, then a jumper must be fitted across terminals 10–11.
- Connect mains supply to terminals marked "Supply".

Wiring diagram

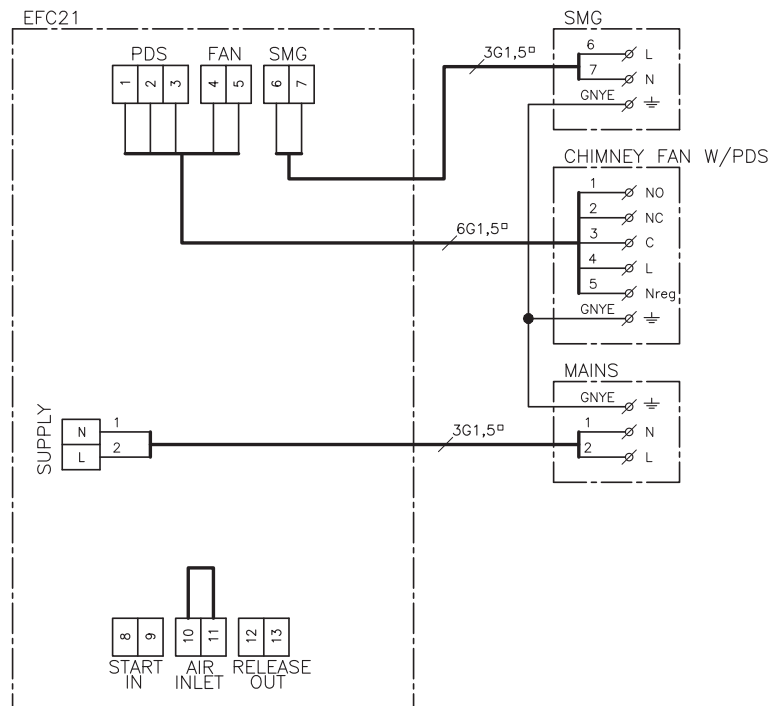

Unit

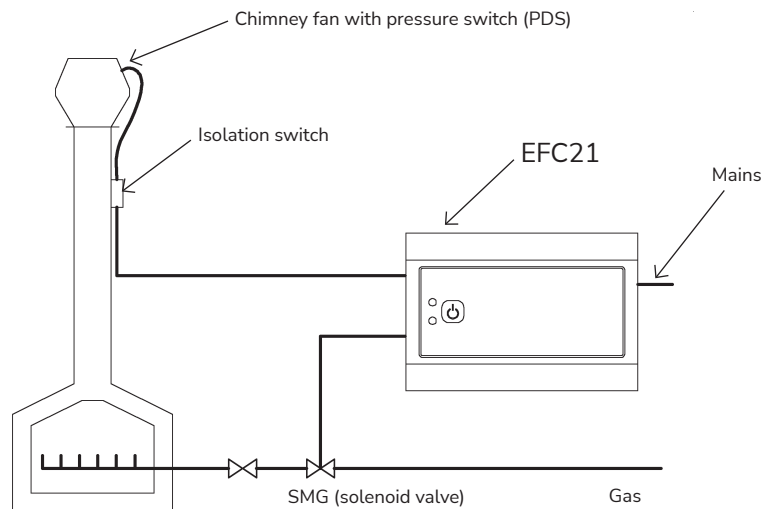

Installation with external ON/OFF

Example showing how a EFC21 controller can be connected directly to a gas fire without having to use an extra SMG. This type of installation requires a fire with a controller that has flame-detection and automatic ignition – or a permanent pilot light. If there is insufficient chimney draught (detected by the fan pressure switch) the controller will switch off the gas fireplace (potential-free switch).

- Connect the mains earth to the earth terminal of the chimney fan.
- Connect the chimney fan and pressure switch to terminals 1–5.
- Optional external ON/OFF switch is connected to terminals 8–9.
- Connect the optional Air inlet monitoring to terminals 10–11.
If this monitoring is not mandatory then a jumper must be fitted across terminals 10–11.
- Connect start/activate burn control to terminals 12–13 (potential-free switch).
- Connect mains supply to terminals marked "Supply".

Wiring diagram

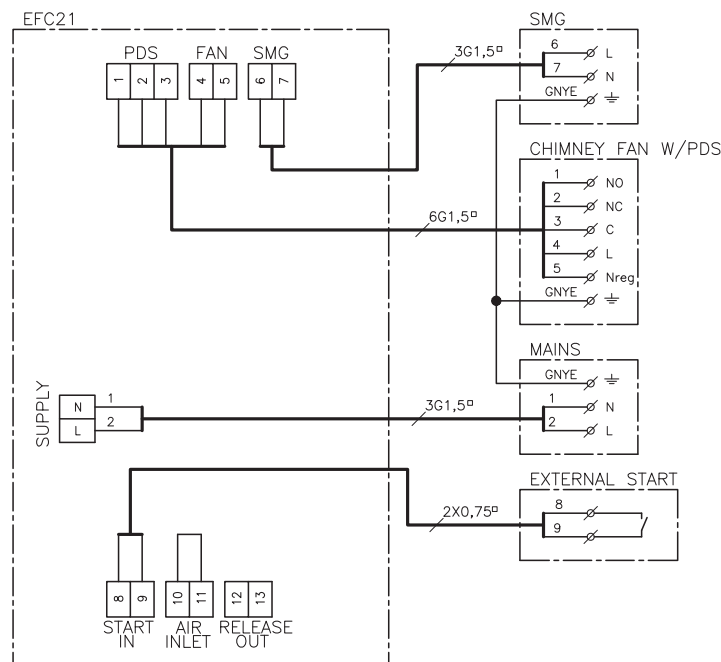

Unit

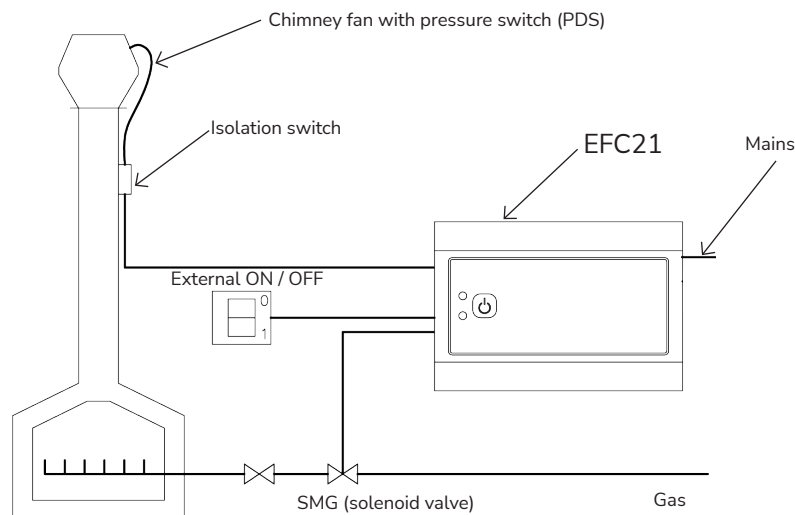

EFC21 coupled directly to a gas fireplace control

Example showing how a EFC21 controller can be connected directly to a gas fire without having to use an extra SMG. This type of installation requires a fire with a controller that has flame-detection and automatic ignition – or a permanent pilot light. If there is insufficient chimney draught (detected by the fan pressure switch) the controller will switch off the gas fireplace (potential-free switch).

- Connect the mains earth to the earth terminal of the chimney fan.
- Connect the chimney fan and pressure switch to terminals 1–5.
- Optional external ON/OFF switch is connected to terminals 8–9.
- Connect the optional Air inlet monitoring to terminals 10–11.
- If this monitoring is not mandatory then a jumper must be fitted across terminals 10–11.
- Connect start/activate burn control to terminals 12–13 (potential-free switch).
- Connect mains supply to terminals marked "Supply".

Wiring diagram

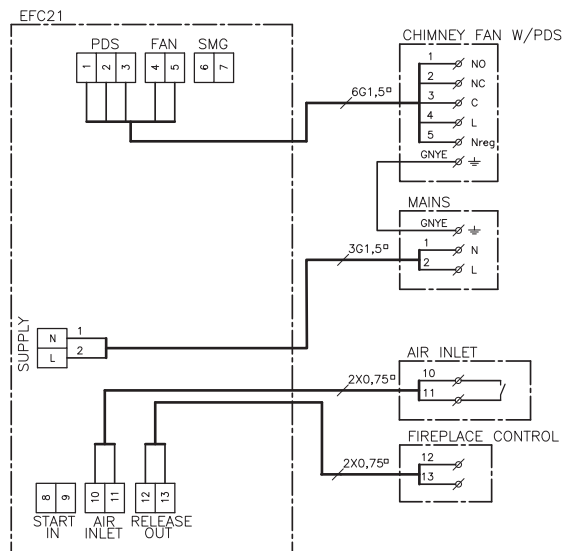

Unit

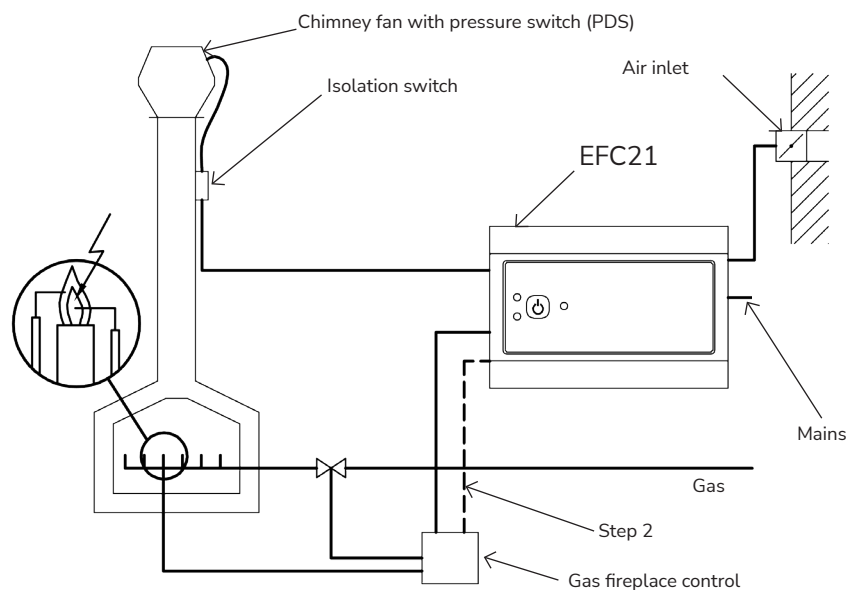

Commissioning



Commissioning is carried out with the control box open.
Only touch components with electrically insulated tools.

All windows and doors must be closed prior to commissioning. If there is another form of ventilation in the room, it should be run at full speed during the commissioning.

DIP switch

Check the factory-set DIP switch setting before commissioning (Fig. 1-J)

	DIP switch	Function	Factory setting	OFF	ON
	1	MANUAL RESET	ON	Automatic RESET following power failure or faulty chimney draught	Manual RESET following power failure or faulty chimney draught
	2	RUN-ON AFTER VENTILATION	OFF	No fan run-on	Fan runs on for three minutes

Service mode



In service mode the PDS and Air inlet safety function are disabled.

- Open control panel.
- Press ON/OFF button (Fig. 1-C).
- If the fire has to be lit during the commissioning then wait until GREEN LED is on, but not flashing.
- Press the service mode button (Fig. 1-I) on the back of the cover.
Alarm LED (Fig. 1-A) will flash RED, and the operating LED (Fig. 1-B) will flash according to the position of the pressure switch – see the table below.

RED	Insufficient chimney draught (C-NC)
GREEN	Sufficient chimney draught (C-NO)
YELLOW	No signal from pressure switch. Check the wiring

The service mode will deactivate automatically after 30 minutes or the next time the ON/OFF button is pressed.

Setting the potentiometer

- The potentiometer (Fig. 1-K) is set to maximum by turning clockwise.
- Slowly adjust the fan speed using the potentiometer. Check there are no spillages by thoroughly checking the edge of the fireplace.
- If there is some leakage, increase the fan speed until leakage from the fireplace is no longer detectable.

Setting the pressure switch

The pressure switch is normally fitted in the chimney fan.

- Set the pressure switch to a minimum by turning anti-clockwise.
- Slowly increase the pressure switch setting until it cuts out (you will hear a click) or until the operating LED (Fig. 1-B) changes from GREEN to RED.
- Make a note of the pressure switch setting at cut-off.
- Set the pressure switch to 10 Pa below the previously noted cut-off value.
- Press ON/OFF button (Fig. 1-C). Service mode is now deactivated.

Testing the commissioning set-up

- Prior to the test, the required speed of the fan must be determined and adjusted according to fireplace manufacturer instruction.
- Check the start-up function after the commissioning by pressing the ON/OFF button.
- Start fireplace.
- Check there is no leakage (all doors and windows must be closed) If some other type of ventilation is installed, it must be on and running at full speed.
- If a leak is detected, repeat the commissioning.
- After running for ten minutes with no leakage, turn the isolation switch off and the fail-safe function is being checked. The fireplace should cut-out after 15 seconds after the pressure switch has cut-off. Remember to switch the isolation switch back on.
- Fit the cover.
- Inform the end user about the controller functions and leave the instructions with the end user.

Daily use

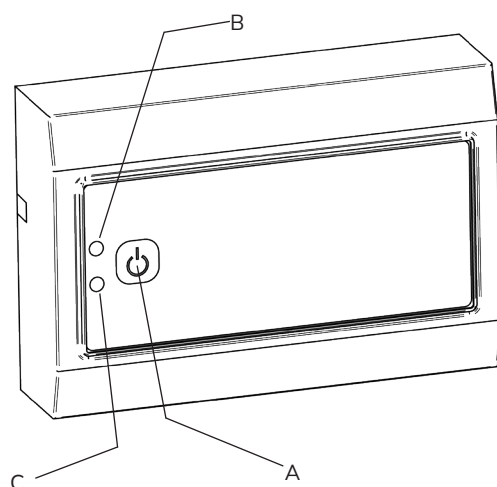

Using the EFC controller	<ul style="list-style-type: none"> • Press the ON/OFF button (A). • The operating LED (B) will flash GREEN until the correct chimney draught is confirmed. • If it flashes YELLOW, then the Air inlet must be opened. The operating LED will then become GREEN and the fireplace can be lit. • To stop the fan press the ON/OFF button.
External ON/OFF switch	<ul style="list-style-type: none"> • The ON/OFF switch can be used to start, stop and reset the controller. • If the external ON/OFF switch is used, it has priority over the control panel.

NB! The switch must be in the OFF position before the controller can be re-started.

Operating LED

Observation (B)	Type of fault
Flashing RED	No start-up signal from the safety circuit Typically, because the fan is restarted while it is still running
Flashing GREEN	The fan has started and the controller is waiting for the chimney-draught-ok signal
Flashing YELLOW	Chimney draught is confirmed correct but signal from the Air inlet is missing
Constant GREEN	Start up ok and the fire can be lit
Constant YELLOW	The ventilation function is active and the fire is OFF

Alarm LED

Constant RED indicates a power failure has occurred.

To reset and start the controller, press the ON/OFF button once. If the alarm LED (C) activates during operation, press the ON/OFF button twice to stop the fan and restart the controller. If the alarm LED remains on after reset, please refer to the "Troubleshooting" section.

Extra function

Press the ON/OFF button (A) for at least four seconds to increase the fan's operating speed. If the controller is switched off, the fan speed will be reset.

Troubleshooting

Start

Observation		Type of fault	Solution
Operating LED	Alarm LED		
	Constant RED	Power failure	1. Press the ON/OFF button twice or the external ON/OFF button to reset and start up
Flashing RED		Safety monitoring fault (pressure switch)	1. Check the wiring 2. The PDS setting may be too high 3. Adjust the pressure switch setting
Flashing GREEN		Unit fault	1. Check the isolation switch 2. Check the fan is running. If it is not running, check wiring to the fan and PDS 3. Check that the flue, chimney and/or chimney fan are not blocked 4. Check the flow sensor in the chimney fan 5. Check settings and go through the commissioning again
Flashing YELLOW		Air volume/Air inlet signal	1. Check the Air inlet is open 2. Check the switch and wiring 3. If the installation does not have an Air inlet, check that there is a jumper across terminals 10–11
Flashing RED, GREEN or YELLOW	Flashing RED	Service mode	Press the ON/OFF button
No response	No response	Check remote control battery	Change battery

Operating

Observation		Type of fault	Solution
Operating LED	Alarm LED		
Constant GREEN	Constant RED	Insufficient chimney draught, the correct draught is being established	1. Press the ON/OFF button, or if the external ON/OFF switch is in use, turn it OFF before resetting 2. Press the ON/OFF button or use the external ON/OFF switch to restart
Flashing GREEN	Constant RED	Faulty chimney draught	1. Check the isolation switch 2. Check the fan is running. If it is not running, check wiring to the fan 3. Check that the flue, chimney and/or chimney fan are not blocked 4. Check the flow sensor in the chimney fan 5. Check settings and redo the commissioning again

Approvals

Third part approvals

The EFC21 is certified by GASTEC and have the certification number: PIN: 0063 BT1395

Safety check by Gas Safe Register

Gas appliances should be checked for safety once a year by a installer registered in the Gas Safe Register. Details of local installers can be obtained by ringing the gas safe register on 0800 408 5500 or by accessing the website at <https://www.gassaferegister.co.uk/>



UK Conformity Assessed



**Exodraft a/s
Industrivej 10
DK-5550 Langeskov**

Hereby declares that the following products:

EFC21

Were manufactured in conformity with the provisions of the following regulations:

The Supply of Machinery (Safety) Regulations 2008

Electrical Equipment (Safety) Regulations 2016

Electromagnetic Compatibility Regulations 2016

Langeskov, 01-11-2022
Managing Director
Anders Haugaard



Declaration of Conformity

DK: EU-Overensstemmelseserklæring
 GB: Declaration of Conformity
 DE: EU-Konformitätserklärung
 FR: Déclaration de conformité de l'Union Européenne
 NO: EU-Samsvarserklæring
 PL: EU Deklaracja zgodności

NL: EU-Conformiteits verklaring
 SE: EU-Överensstämmelsedeklaration
 FI: EU-Vaatimustenmukaisuusvakuutus
 IS: ESS-Samræmisstaðfesting
 IT: Dichiarazione di Conformità Unione Europea

exodraft

Exodraft a/s
 Industrivej 10
 DK-5550 Langeskov

Erklærer på eget ansvar, at følgende produkter:
 Hereby declares that the following products:
 Erklärt hierdurch auf eigene Verantwortung, daß folgende Produkte:
 Déclare, sous sa propre responsabilité, que les produits suivants:
 Erklærer på eget ansvar at følgende produkter:
 Niniejszym oświadczam, że następujące produkty:

Veklaart dat onderstaande producten:
 Deklarerar på eget ansvar, att följande produkter:
 Vastaa siltä, että seuraava tuote:
 Staðfesti à eigin àbyrgð, að eftirfarandi vörur:
 Dichiaro con la presente che i seguenti prodotti:

EFC21

Som er omfattet af denne erklæring, er i overensstemmelse med følgende standarder:
 Were manufactured in conformity with the provisions of the following standards:
 Die von dieser Erklärung umfaßt sind, den folgenden Normen:
 Auxquels s'applique cette déclaration sont en conformité avec les normes ci-contre:
 Som er omfattet av denne erklæring, er i samsvar med følgende standarder:
 Zostały wyprodukowane zgodnie z warunkami określonymi w następujących normach:

Zijn vervaardigd in overeenstemming met de voorschriften uit de hieronder genoemde normen en standaards:
 Som omfattas av denna deklaration, överensstämmer med följande standarder:
 Jota tämä selvitys koskee, on seuraavien standardien mukainen:
 Sem eru meðtalin í staðfestingu Pessari, eru í fullu samræmi við eftirtalda staðla:
 Sono stati fabbricati in conformità con le norme degli standard seguenti:

EN 60335-1, EN 60335-2-80, DS/EN ISO 12100: 2011

I.h.t bestemmelser i direktiv:
 In accordance with
 Entsprechen gemäß den Bestimmungen der folgenden Richtlinien:
 Suivant les dispositions prévues aux directives:
 I.h.t bestemmelser i direktiv:
 Zgodnie z:

En voldoen aan de volgende richtlijnen:
 Enligt bestämmelserna i följande direktiv:
 Seuraavien direktiivien määräysten mukaan:
 Med tilvisun til ákvarðana eftirlits:
 In conformità con le direttive:

Maskindirektivet:
 The Machinery Directive:
 Richtlinie Maschinen:
 Directive Machines:
 Maskindirektivet:
 Dyrektywę maszynową:

De machinerichtlijn:
 Maskindirektivet
 Konedirektiivi:
 Vælaeftirlitið:
 Direttiva Macchinari:

2006/42/EF-EEC/-EWG/-CEE

Lavspændingsdirektiv:
 The Low Voltage Directive:
 Niederspannungsrichtlinie:
 Directive Basse Tension:
 Lavspenningsdirektivet:
 Dyrektywę Niskonapięciową

De laagspanningsrichtlijn:
 Lågspänningsdirektivet:
 Pienjännitedirektiivi:
 Smáspennueftirlitið:
 Direttiva Basso Voltaggio:

2014/35/EC

EMC-direktivet:
 And the EMC Directive:
 EMV-Richtlinie:
 Directive Compatibilité Electromagnétique:
 EMC-direktivet:
 Dyrektywę EMC – kompatybilności elektromagnetycznej

En de EMC richtlijn:
 EMC-direktivet:
 EMC-direktiivi:
 EMC-efirlitið:
 Direttiva Compatibilità Elettromagnetica:

2014/30/EC

Langeskov, 01-11-2022
 Adm. direktør
 Managing Director
 Anders Haugaard

Algemeen directeur
 Geschäftsführender Direktor
 Président Directeur Général
 Verkställande direktör
 Toimitusjohtaja
 Framkvemdastjóri
 Direttore Generale

DK: Exodraft a/s

Industrivej 10
DK-5550 Langeskov
Tel: +45 7010 2234
Fax: +45 7010 2235
info@exodraft.dk
www.exodraft.dk

SE: Exodraft a/s

Valhallavägen 9A
SE-375 30 Mörrum
Tel: +46 (0)8-5000 1520
info@exodraft.se
www.exodraft.se

NO: Exodraft a/s

Storgaten 88
NO-3060 Svelvik
Tel: +47 3329 7062
info@exodraft.no
www.exodraft.no

UK: Exodraft Ltd.

24 Janes Meadow, Tarleton
GB-Preston PR4 6ND
Tel: +44 (0)1494 465 166
Fax: +44 (0)1494 465 163
info@exodraft.co.uk
www.exodraft.co.uk

DE: Exodraft a/s

Niederlassung Deutschland
Industriestraße 14
DE-55768 Hoppstädten-Weiersbach
Tel: +49 6782 989 590
Fax: +49 6782 989 5929
info@exodraft.de
www.exodraft.de

FR: Exodraft sas

78, rue Paul Jozon
FR-77300 Fontainebleau
Tel: +33 (0)6 3852 3860
info@exodraft.fr
www.exodraft.fr

Your energy. Optimized.

exodraft