

Heat Recovery

Basic Plate

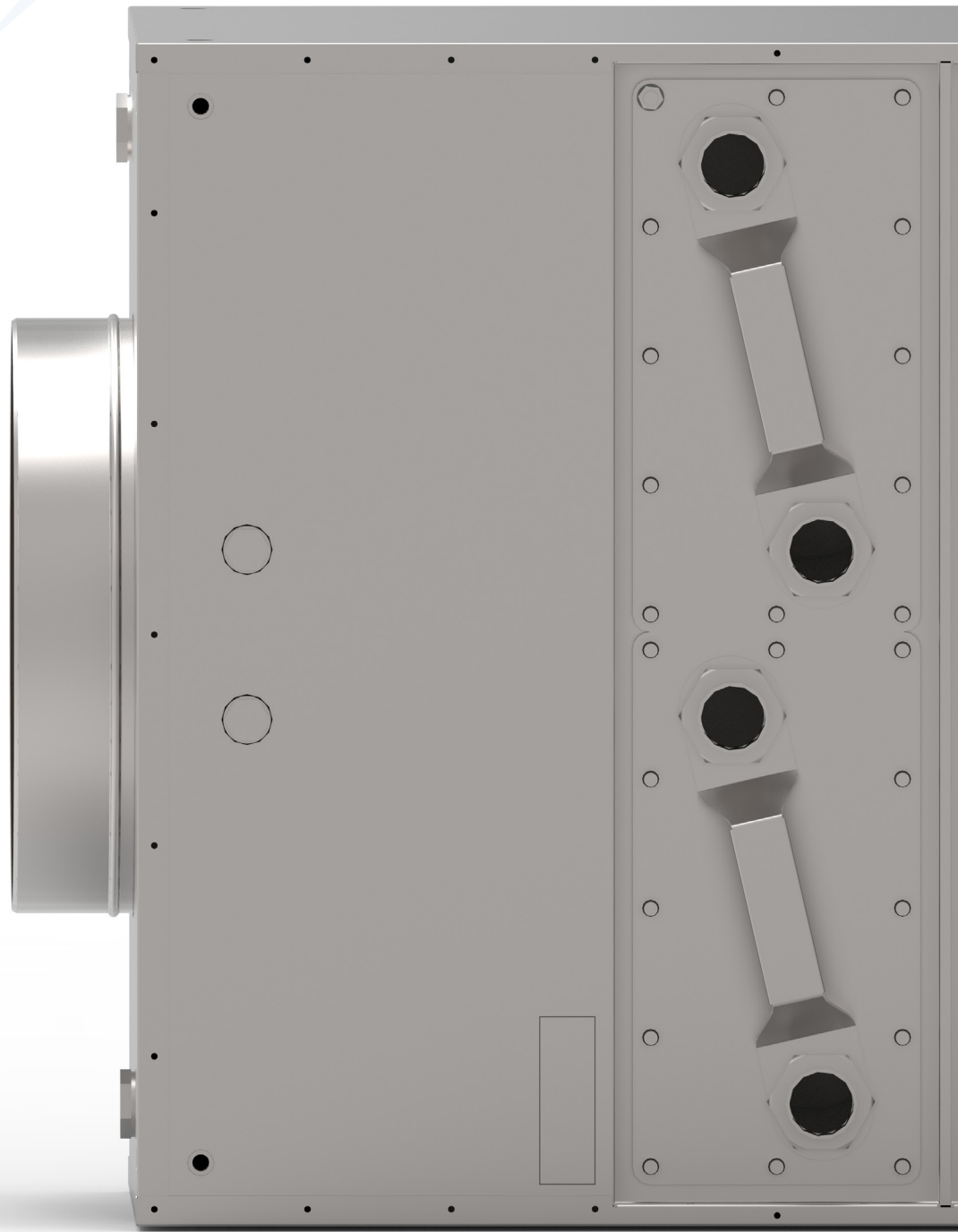

UK | Read and save these instructions!

exodraft
Your energy. Optimized.

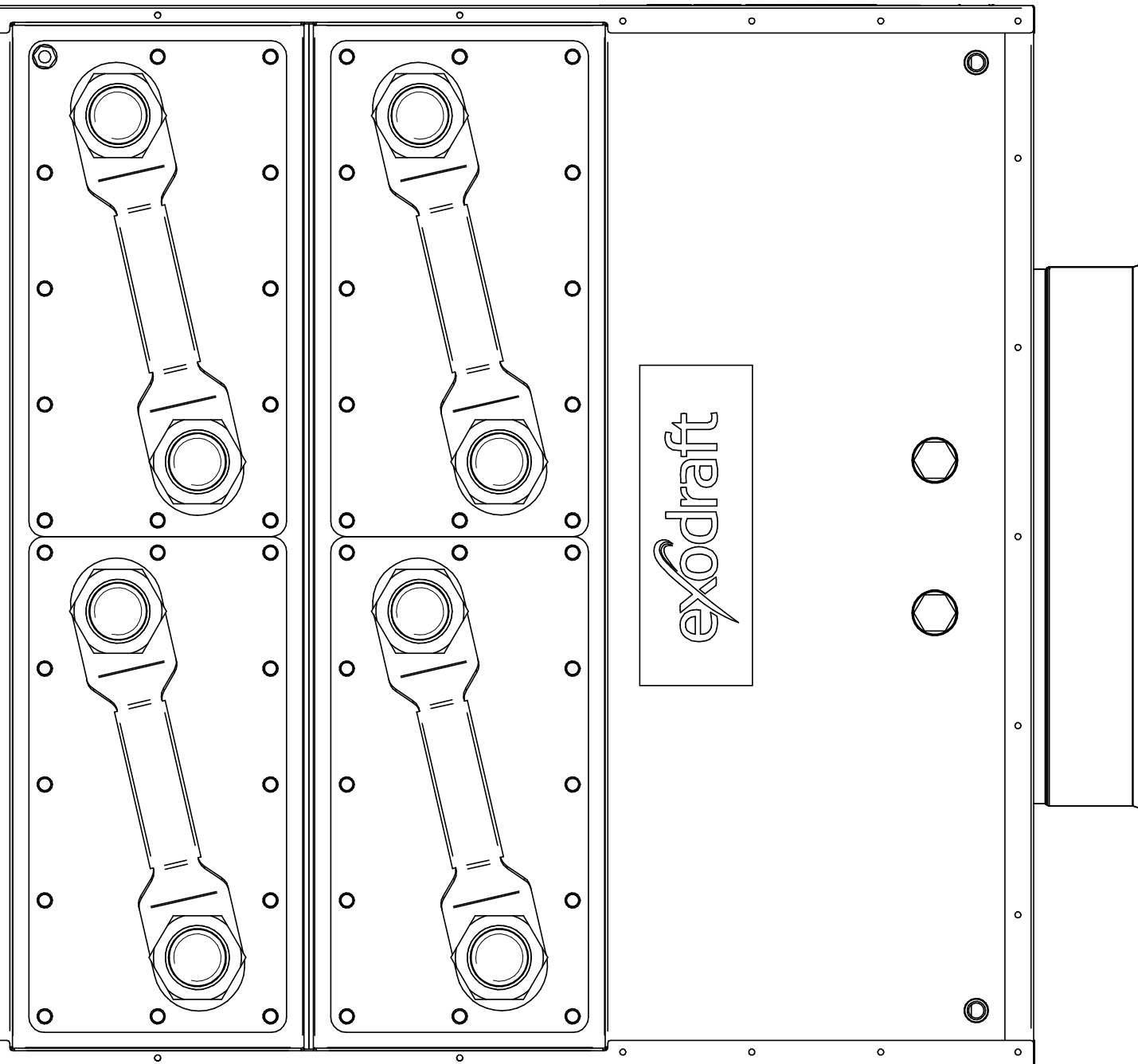

exodraft

Heat Recovery | Basic Plate

Content

Product information	7
Scope of supply	7
Accessories and spare parts	8
Warranty	9
Technical specifications	10
Mechanical installation	14
Orientation	14
Placement	15
Drain connection	16
Mounting	17
Mounting points	18
Connection	20
Installation without water connection	23
Electrical installation	24
Placement of Safety Thermostat	24
Operating conditions	25
Primary-/Flue Gas Side	25
Secondary-/Liquid Side	25
Startup and configuration	26
System startup	26
Maintenance and troubleshooting	27
Care and cleaning	27
Troubleshooting	28
System pressure	29
UK Conformity Assessed	34
Declaration of Conformity	35



How to use this manual

This manual has been prepared based on the specific product and contains relevant technical information and installations guides.

Accessories and spare parts are not covered by this manual. Please refer to the individual manuals of these components.

This installation manual does not contain any system design documentation.

Failure to observe instructions marked with a danger symbol may result in personal injury and/or damage to the product.

Errors and omissions excepted.



Disposal

Electrical and electronic equipment (EEE) often contain materials, components and substances that may harm the environment or be hazardous to your health. Products (WEEE) marked with the 'crossed-out wheeled bin' symbol should be disposed of separately from other waste at the end of its life. Though legislation may differ from country to country we strongly advise that electrical and electronic waste is separated from other waste and disposed of according to national legislation to protect the environment and personnel that may come into contact with waste.

Symbols

The following symbols may be used in the manual to draw attention to danger or risk of personal injury or damage to the product.



General prohibition

Failure to observe instructions marked with the prohibited symbol may result in extreme danger or serious personal injury.



General attention

Marks a dangerous situation that, in the worst-case scenario, can cause serious personal injury or significant damage to the product.



General warning

Failure to observe instructions marked with a danger symbol may result in personal injury and/or damage to the product.



Electricity hazard/High Voltage

Marks a situation in which caution is advised due to the risk of high voltage electric shock which can cause serious personal injury or significant damage to the product.



Connect an earth terminal to the ground

Failure to observe instructions marked with a danger symbol may result in personal injury and/or damage to the product.



Permitted and approved

Permitted and approved method of installation.



Prohibited and not approved

Prohibited and not approved method of installation.



Warning

To minimise the risk of fire, electric shock, personal injury and/or damage to the product please observe the following:

- Please always read the manual and only use the product in accordance with the manufacturer's instructions. If in doubt, contact one of the Exodraft specialized dealers.
- All installations must be carried out by properly qualified personnel in accordance with national legislation and regulations.
- Prior to servicing the product, the heat source must be shut off and cooled.
- Please ensure that the heat source is not turned back on inadvertently.
- A safety thermostat (ST110) and/or safety valve must be installed and connected to the burner, ensuring disconnection in case of excessive temperatures. The switch must comply with EN 14597.

Product information

An Exodraft Basic Plate is a compact heat recovery unit for use in Exodraft system solutions.

The heat exchanger is a compact module that utilizes the passing heat (air to water).

Basic Plate is used primarily in industrial and commercial plants with long operating hours and high exit temperatures (max 600°C) in flue pipes and chimneys.

Basic Plate is easy and fast to maintain and clean.

Typically, it is used in bakeries, the food processing industry, and in metal processing.

The recovered and stored energy may be used for things like production of utility water, water for heating, cleaning, or process water.

Basic Plate can be used in heated process air from gas, electricity, and oil (may require special alloy for exchanger) for heated heat sources.

Several Basic Plate units can be combined modularly.

All parts affected by flue gas are made of stainless steel EN 1.4404.

All exterior parts are made of stainless steel EN 1.4301.

The Basic Plates limitations

- Strictly for indoor installation
- Range of operation: 250-1000 kW (nominal burner power input)
- Max. temperature 600°C
- Process air or flue gas must be of a nature that does not clog up the exchangers in short time

To find out more about heat recovery visit www.exodraft.com

Scope of supply

- Exodraft Basic Plate
- Installation manual and user instructions
- Pallet*
- Straps*
- Screws*
- Transportation safety brackets*

*For transportation only. Be aware to disconnect these parts before installation.

Accessories and spare parts

The table below shows the spare parts available for the Basic Plate models.

Spare parts

2400282	Heat exchanger gasket
---------	-----------------------

3200988	Exchanger GLX30-119 WT (Copper brazed)
---------	--

3200989	Exchanger GLX30-139 WT (Copper brazed)
---------	--

*This manual does not describe the specific use of spare parts. We refer to the separate manuals for such components.

For more details contact your Exodraft dealer.

Warranty

All Exodraft products are covered by a 2-year guarantee as per European consumer rights legislation. For some countries an extended period of guarantee may apply depending on either national legislation or other clearly stipulated conditions. Customer complaints must be handled by a specialised dealer or wholesaler (preferably where the Exodraft product has been bought originally). An updated list of Exodraft specialised dealers can be found on our website for the country in question.

Exodraft products must always be installed by properly qualified personnel. Exodraft reserves the right to change these guidelines without prior notice.

The warranty and liability does not cover instances regarding personal injury or damage to property or the product that can be ascribed to one or more of the following causes:

- Failure to follow this installation and operation manual
- Incorrect installation, start-up, maintenance or servicing
- Improper repairs
- Unauthorised structural modifications made to the product
- Installation of additional components that have not been tested/approved with the product
- Any damage resulting from continued use of the product despite an evident defect
- Failure to use original spareparts and accessories
- Failure to use the product as intended
- Exceeding or failure to meet the limit values in the technical data
- Force majeure

Technical specifications

Basic types

Exodraft item number	Type (Basic Plate)	Description	Approximate connection power	Natural gas Nominal flow 250°C λ 1.2
8002300	BP250	Basic housing GLX30 exchanger (Plate), Copper brazed Standard pipe connection dimensions Max. 600°C 1 step on air side	250 kW	600 m ³
8002301	BP250-2	Basic housing GLX30 exchanger (Plate), Copper brazed Standard pipe connection dimensions Max. 600°C 2 steps on air side	250 kW	600 m ³
8002500	BP500	Basic housing GLX30 exchanger (Plate), Copper brazed Standard pipe connection dimensions Max. 600°C 1 step on air side	500 kW	1200 m ³
8002501	BP500-2	Basic housing GLX30 exchanger (Plate), Copper brazed Standard pipe connection dimensions Max. 600°C 2 steps on air side	500 kW	1200 m ³
8002600	BP750	Basic housing GLX30 exchanger (Plate), Copper brazed Standard pipe connection dimensions Max. 600°C 1 step on air side	750 kW	1700 m ³
8002601	BP750-2	Basic housing GLX30 exchanger (Plate), Copper brazed Standard pipe connection dimensions Max. 600°C 2 steps on air side	750 kW	1700 m ³
8002700	BP1000	Basic housing GLX30 exchanger (Plate), Copper brazed Standard pipe connection dimensions Max. 600°C 1 step on air side	1000 kW	2300 m ³
8002701	BP1000-2	Basic housing GLX30 exchanger (Plate), Copper brazed Standard pipe connection dimensions Max. 600°C 2 steps on air side	1000 kW	2300 m ³
8002800	BP2000	Basic housing GLX30 exchanger (Plate), Copper brazed Standard pipe connection dimensions Max. 600°C 1 step on air side	2000 kW	4600 m ³
8002801	BP2000-2	Basic housing GLX30 exchanger (Plate), Copper brazed Standard pipe connection dimensions Max. 600°C 2 steps on air side	2000 kW	4600 m ³

Standard components

1	Cabinet
2	Heat exchanger
3	Inlet connection
4	Outlet connection
5	1" drain (all 1" connections are drains)
6	½" measuring point (all ½" connections are measuring points)
7	M12 thread for fastening (there is a total of three mounting points in each corner of Basic Plate, each with M12 thread)
8	Lifting eye
9	Cover
10	Nameplate
11	Danger/ Caution sign

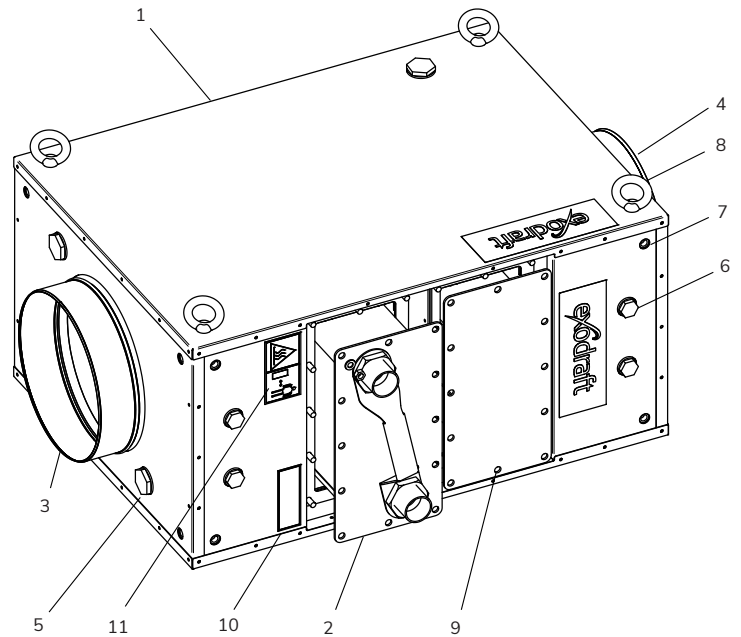

Optional components

PT 1000 temperature transmitter

BP Model	PT 1000 Type	Length
BP250	2400278	300 mm
BP500	2400278	300 mm
BP750	2400310	400 mm
BP1000	2400310	400 mm
BP2000	2400310	400 mm
2400266	Pressure connection for ø8/4 mm hose	
2400067	Double cover plate	
2400068	Single cover plate	
2000335	Silicone hose Ø8/Ø4 mm	
2400355	ST110 safety thermostat	

Technical data

Model	Dimensions [mm]														
	A	B	C	D	E	F	G	H	I	J	K	L	M	N*	O**
BP250/-2	552	475	371	295	753	893	251	52	227	-	72	676	474	251,2	250,5
BP500/-2	552	475	696	620	952	1092	351	52	227	98	72	676	474	351,2	350,5
BP750/-2	1013	937	696	620	952	1092	351	52	227	98	72	876	935	401,2	400,5
BP1000/-2	1013	937	696	620	952	1092	351	52	227	98	72	876	935	501,2	500,5
BP2000/-2	1376	937	1014	620	952	1795	351	52	227	98	72	876	935	701,2	700,5

*Specifies inside sleeve dimensions

**Specifies outside adapter dimensions

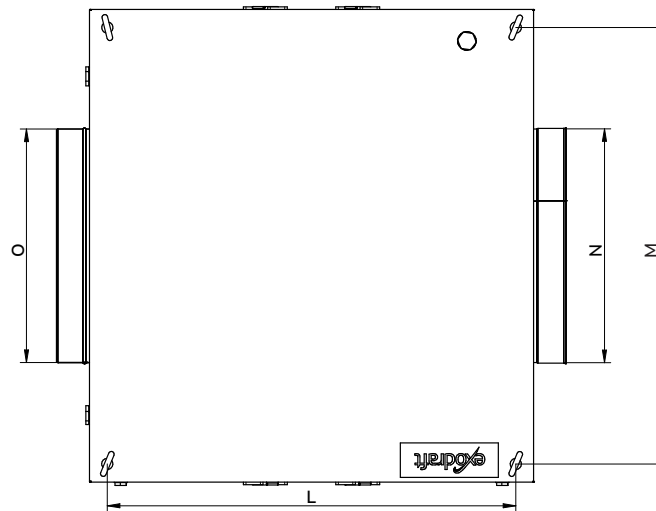
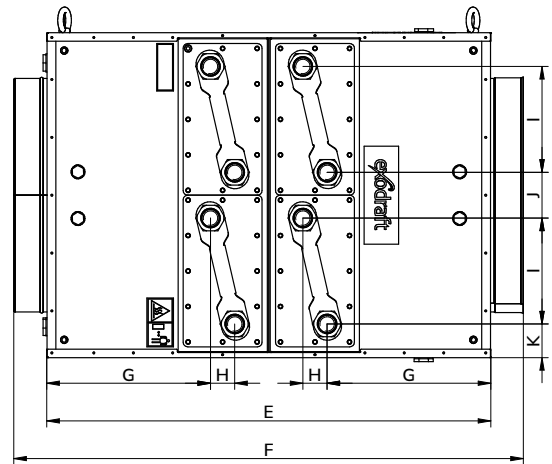
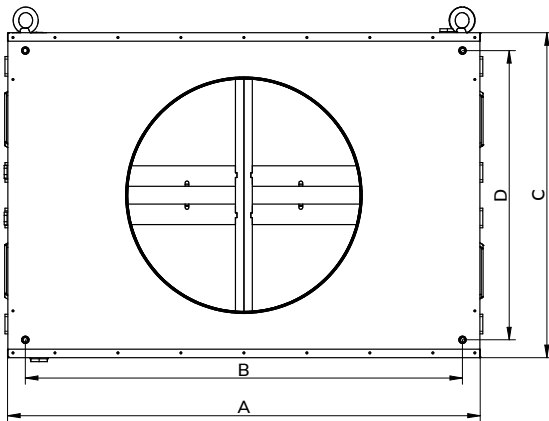

Model	Number of heat exchangers	Weight	
		Incl. heat exchanger [kg]	Excl. heat exchanger [kg]
BP250	1	64	46
BP250-2	2	80	46
BP500	2	114	80
BP500-2	4	150	80
BP750	4	190	130
BP750-2	8	250	130
BP1000	4	196	126
BP1000-2	8	266	126
BP2000	8	550	410
BP2000-2	16	695	410

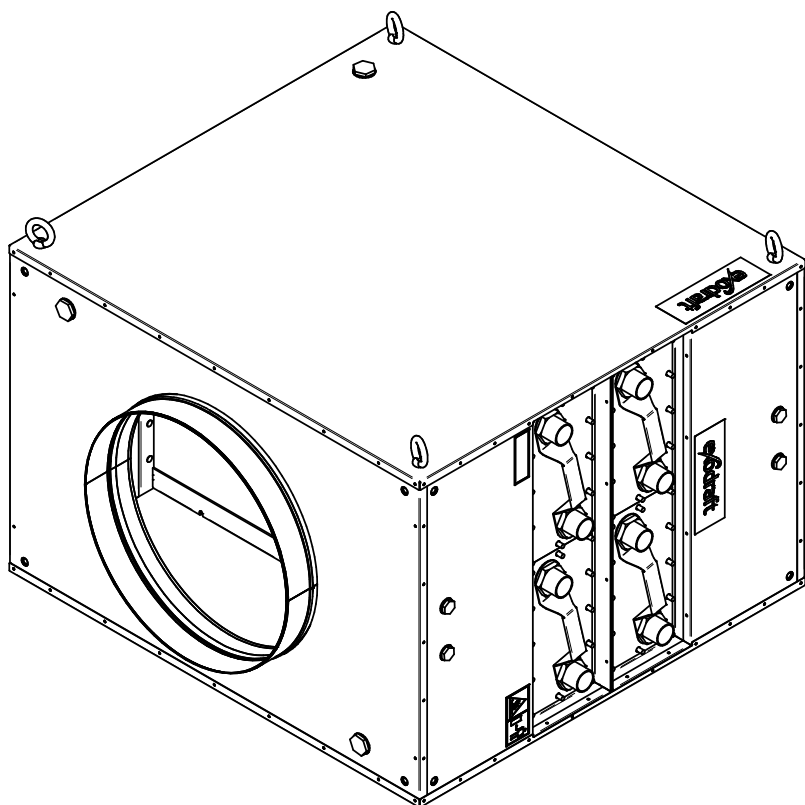

Mechanical installation

Exodraft products must always be installed by properly qualified personnel.

These instructions, applicable standards and relevant safety procedures from the manufacturer must be followed and at the same time the official provisions in force in the country, where the product is installed, must be observed.



CAUTION! If the Exodraft Basic Plate heat recovery unit is not installed, maintained, and/or operated in compliance with the manufacturer's instructions, conditions may arise which could lead to personal injury or material damage.

Orientation

The BP250 and BP500 can be oriented in 3 different ways, and BP750, BP1000 and BP2000 in two different ways.

When orienting Basic Plate heat recovery units, it is important to consider placement of drain connections as well as options for ventilating the heat exchangers.

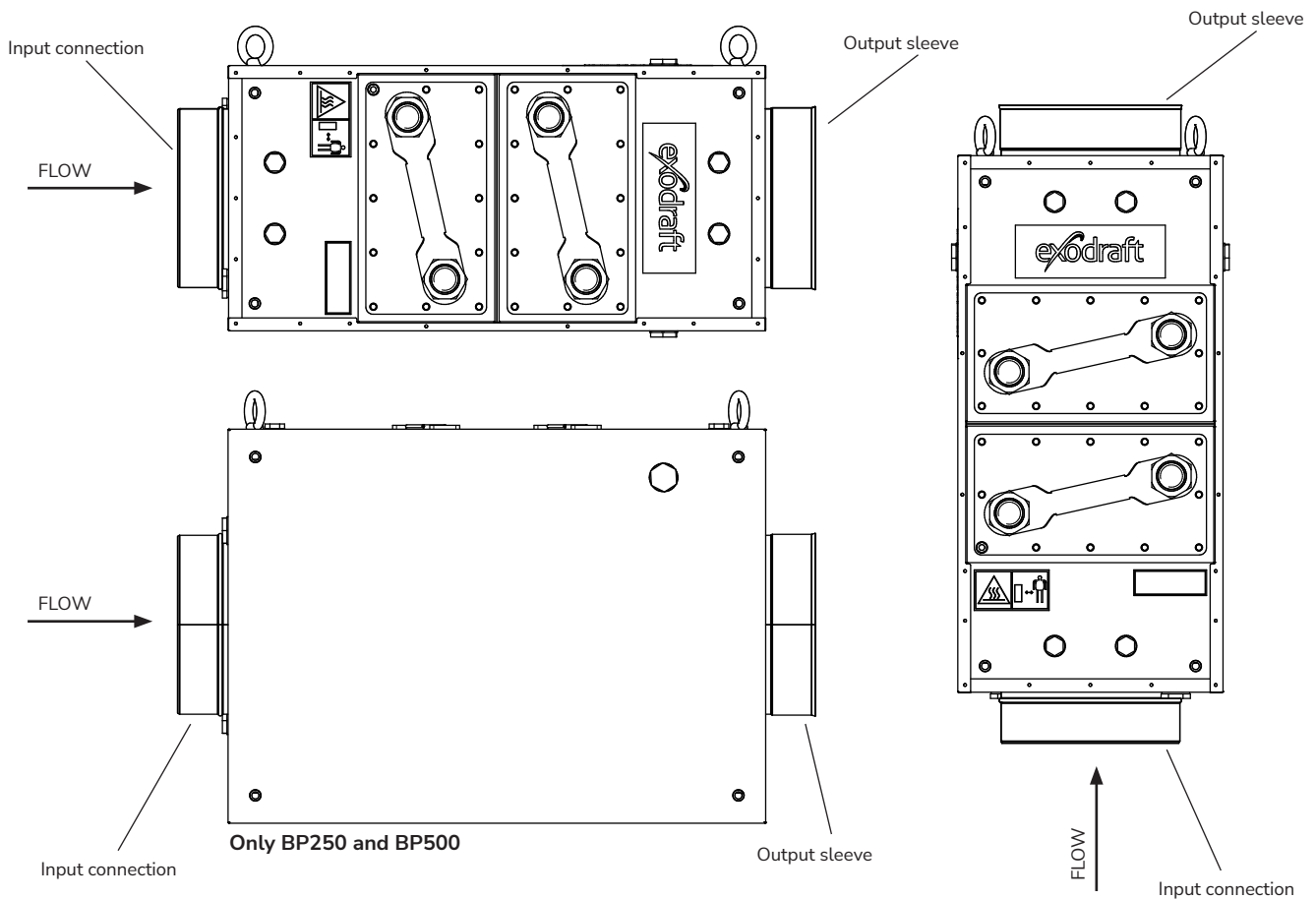

Placement

Placement of the Basic Plate heat recovery unit must be considered carefully.

We recommend placing the Basic Plate as close to the heat source as possible. Furthermore, you must allow for hot surfaces on the Basic Plate.



DANGER! Observe national regulations regarding distance from flammable materials.

If Basic Plate is placed where it is easily accessible, it must be shielded to avoid inadvertent touch and any risk of collision.



CAUTION! Basic Plate must be installed in a way that accommodates pulling out the exchanger for servicing and maintenance.

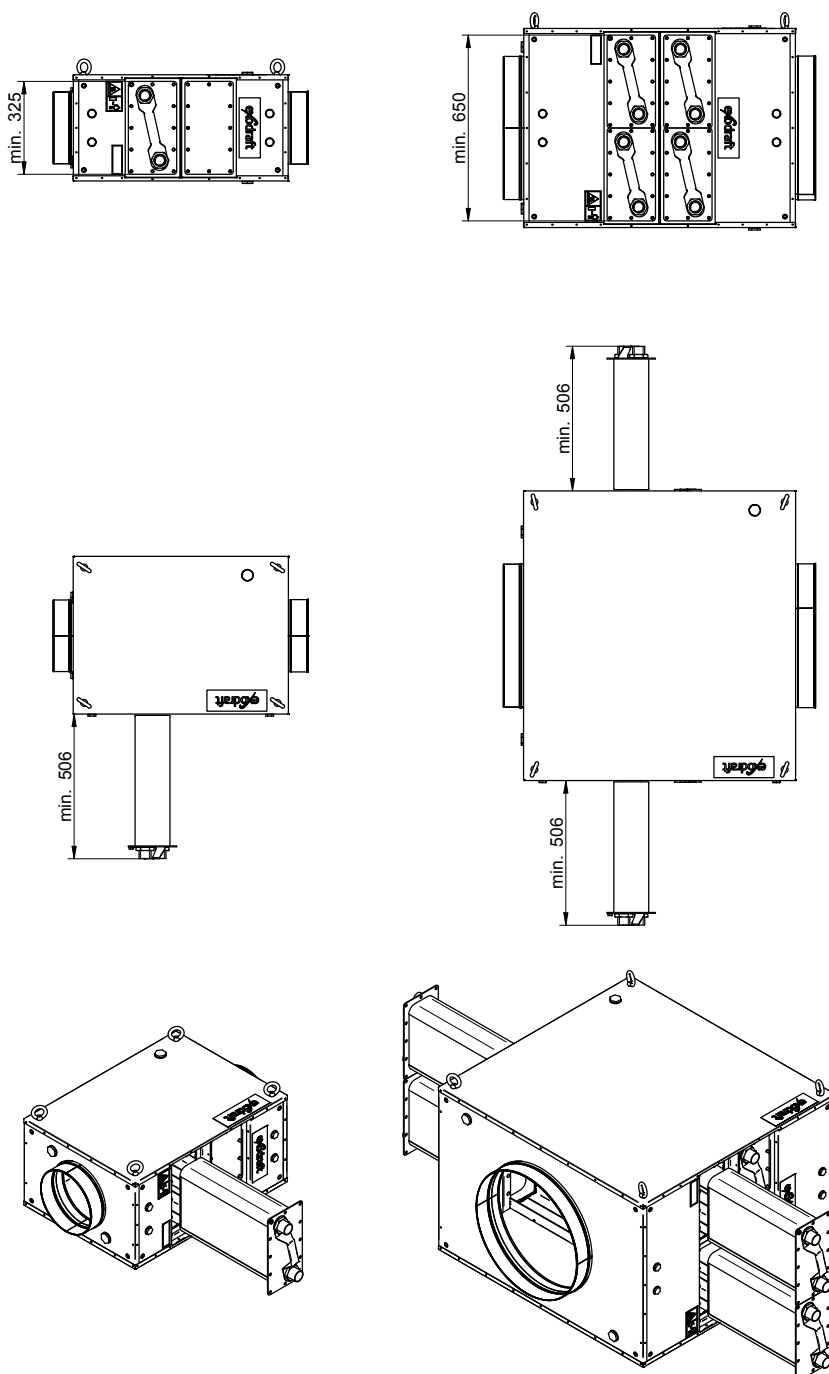

Drain connection

Placement of drain holes in Basic Plate

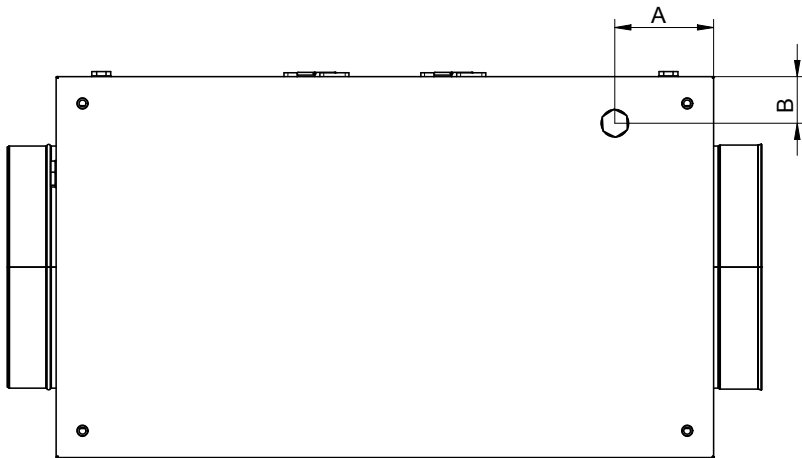

Model	A [mm]	B [mm]
BP250	143	66,5
BP500	143	66,5
BP750	143	66,5
BP1000	143	66,5
BP2000	143	66,5

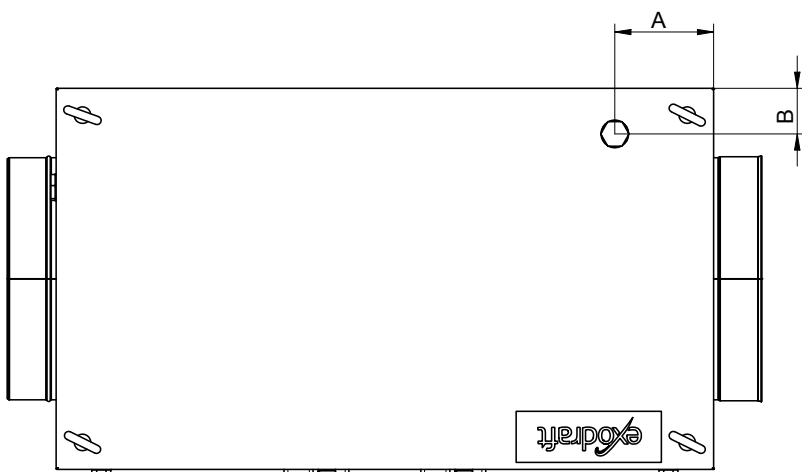
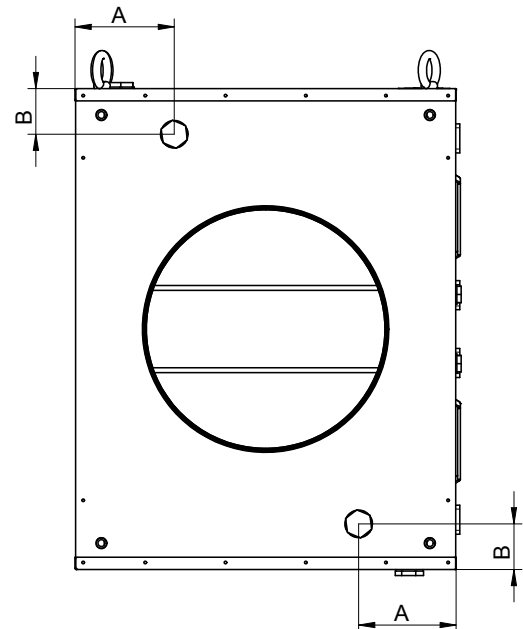
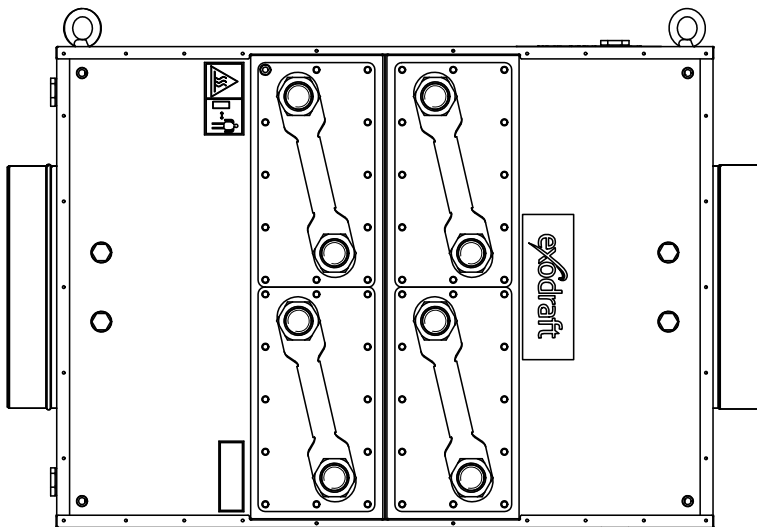

Mounting

The weight must be distributed among at least 4 mounting corners (see next section – Mounting points). Mounting points are only intended to support the weight of the product itself.

Basic Plate is not built to support the weight of any chimney.



DANGER! Max. load on mounting corner 100kg

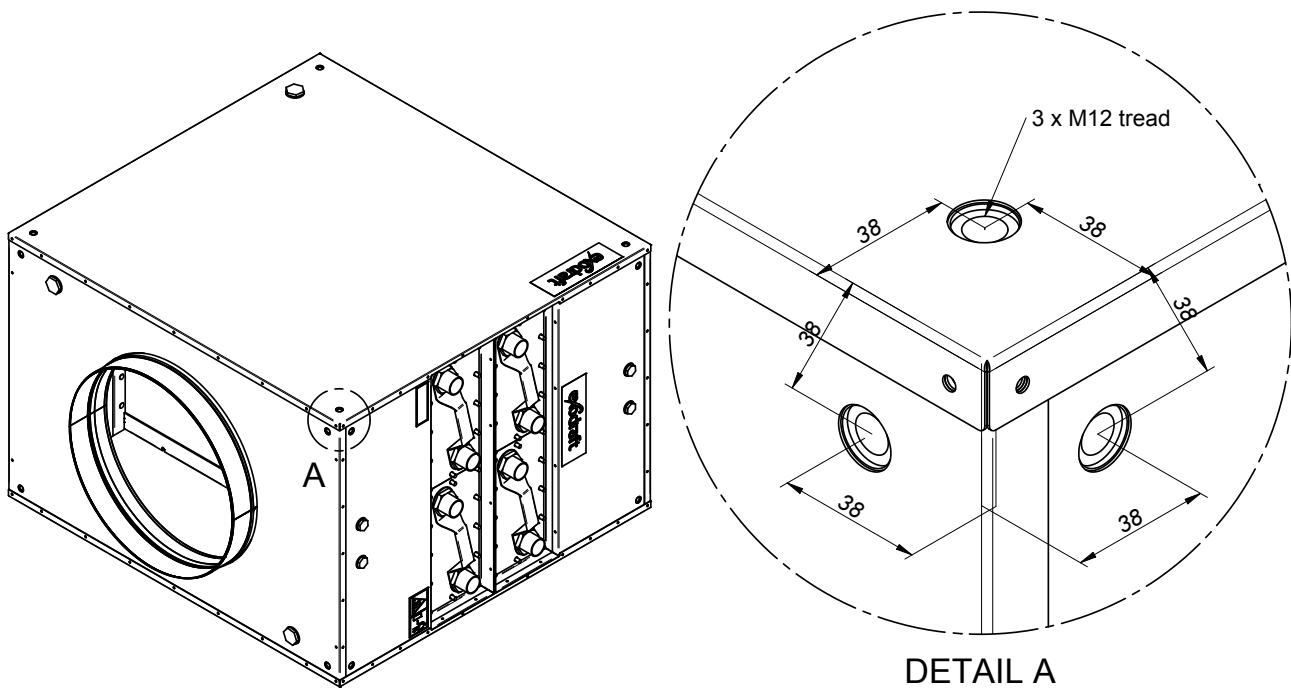

Exodraft item number	Type (Basic Plate)	Weight incl. heat exchangers [kg]	Number of heat exchangers	Weight each heat exchanger [kg]
8002300	BP250	64	1	17,5
8002301	BP250-2	80	2	17,5
8002500	BP500	114	2	17,5
8002501	BP500-2	150	4	17,5
8002600	BP750	190	4	15
8002601	BP750-2	250	8	15
8002700	BP1000	196	4	17,5
8002701	BP1000-2	266	8	17,5
8002800	BP2000	550	8	17,5
8002801	BP2000-2	695	16	17,5

Mounting points

Basic Plate must be fitted in at least four different corners of the product.

In addition, for safety reasons, it must be ensured that the weight of the product is evenly distributed over all four assembly points.

The following examples of this and next page show different solutions to approved and unauthorized mounting methods.

Approved mounting methods

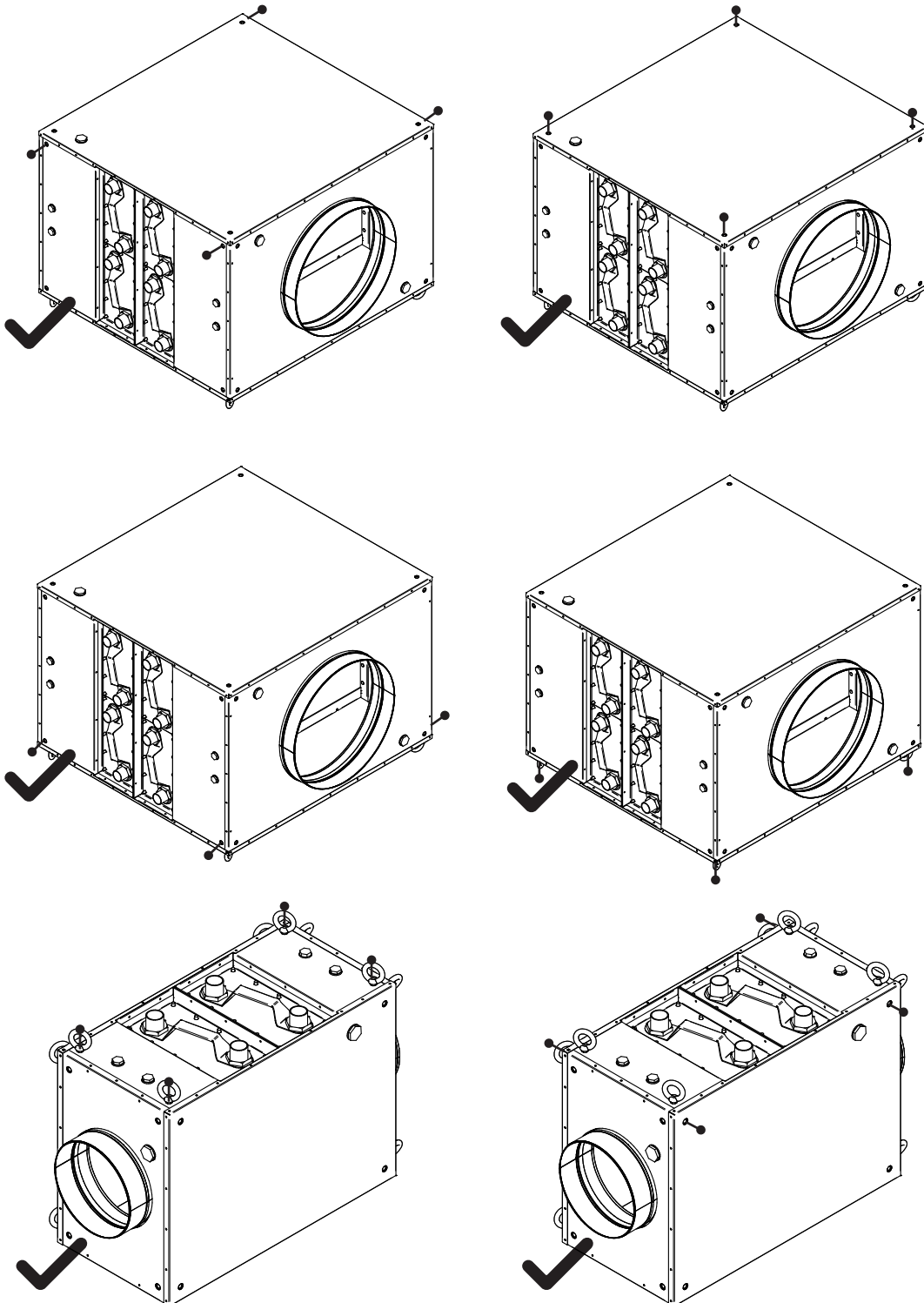

Unapproved mounting methods

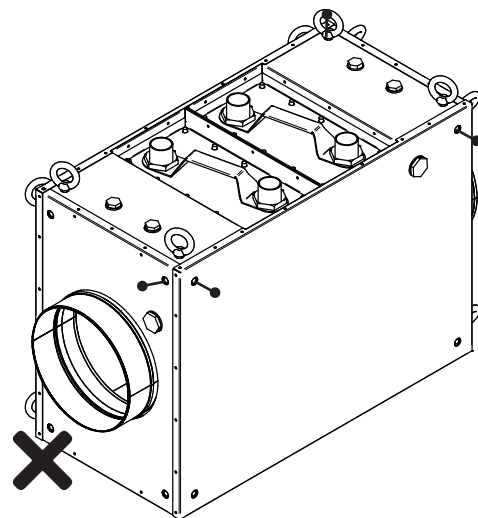
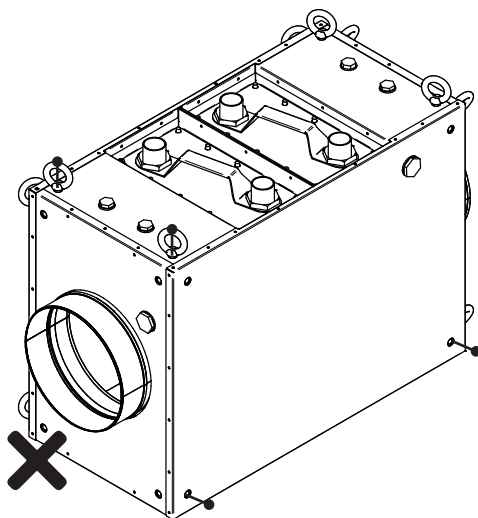
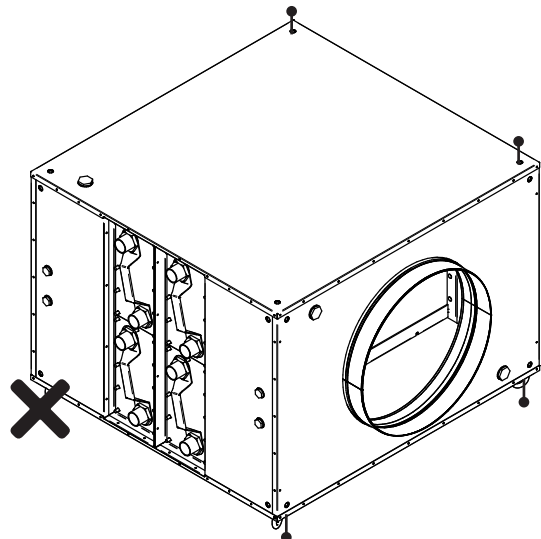
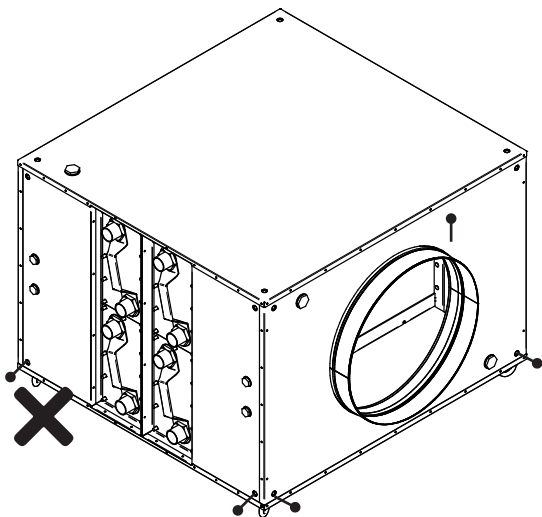
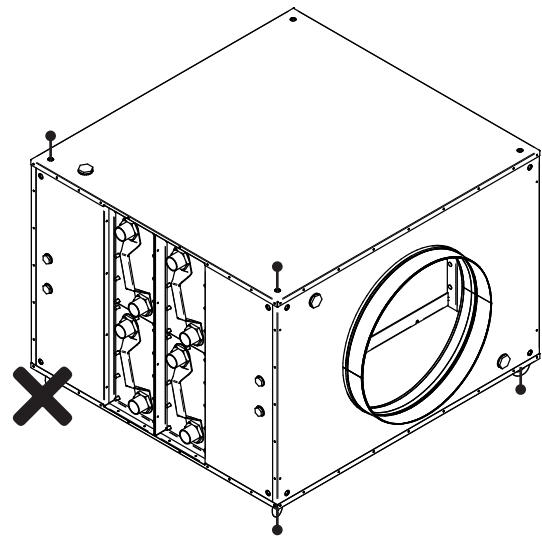
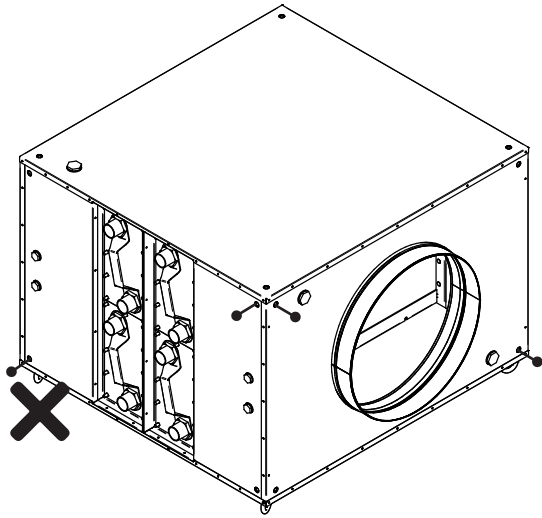

Connection

- Connection on heat exchangers is 1 1/4" outside thread
- Connection to drain is 1" inside thread
- Connection to measuring points is 1/2" inside thread



CAUTION! Basic Plate comes with heat exchangers temporarily mounted for shipping. When installing, the included gaskets, nuts, and washers must be fitted. Tightening the exchanger is done as shown on the illustration below. Nuts are tightened crosswise to 20 Nm.

As a rule, the washer for the heat exchanger can be used only once.

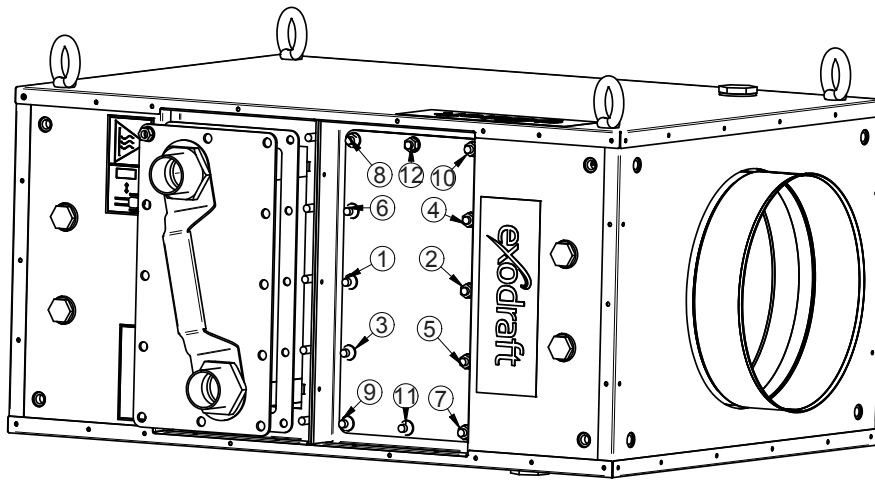

When selecting gasket material, keep in mind that the temperature for drains and measuring points can be the same as the temperature of the flue gas.

We recommend installing a water trap on the drain connection. The water trap should be placed a good distance from the Basic Plate to avoid the water evaporating.



DANGER! The safety thermostat must be fitted on the supply side.
Pressure relief valve must be fitted to the water circuit.
See recommended system pressure in section about Maintenance and Troubleshooting.



CAUTION! If the drain is connected to the sewer system, you must ensure that condensate complies with any emission requirements.

Water connection for BP250

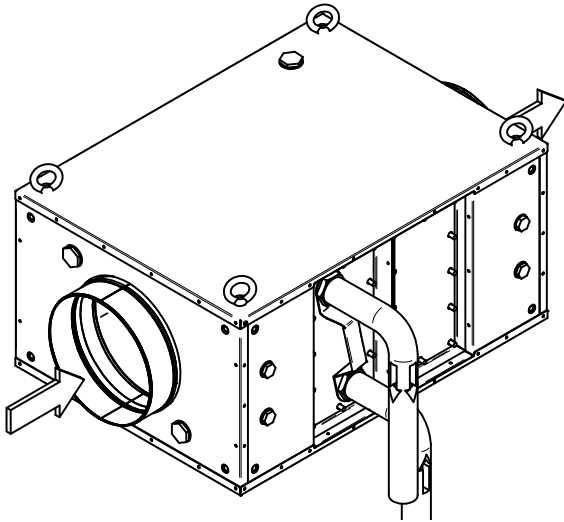

Water connection for BP250-2

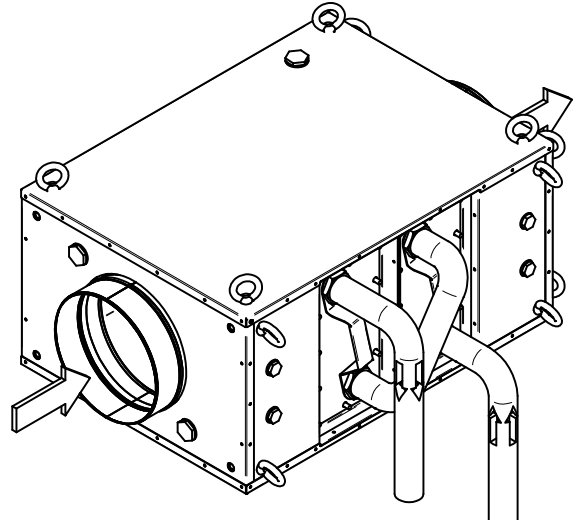

Water connection for BP500

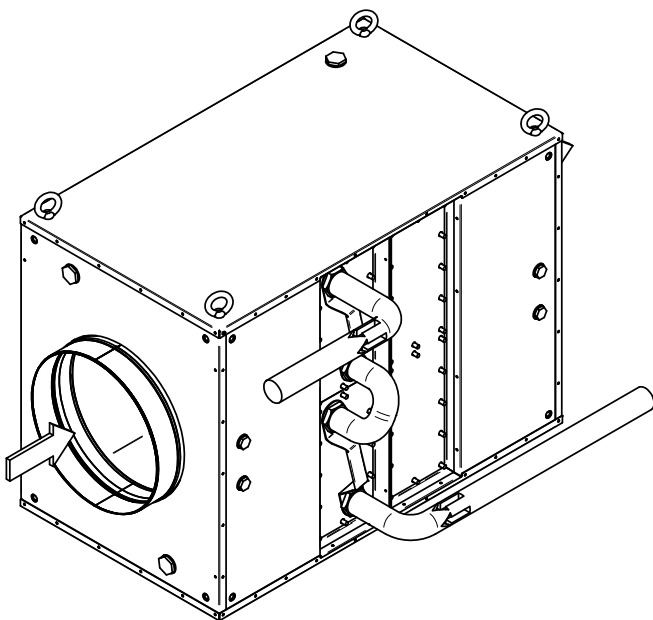

Water connection for BP500-2

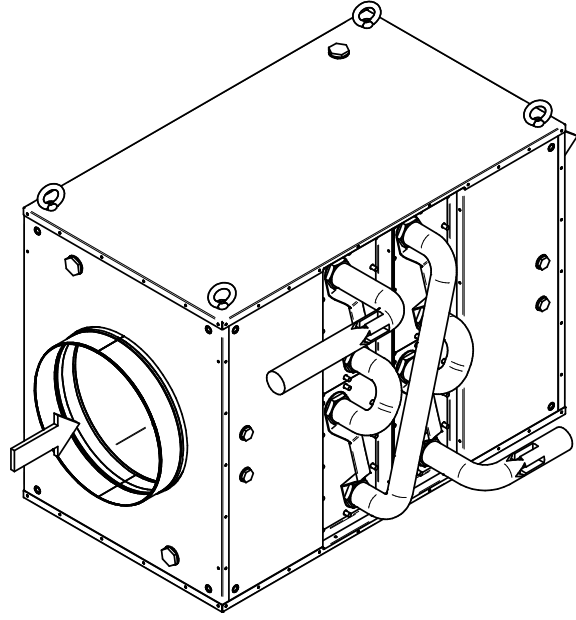

Water connection for BP750/1000

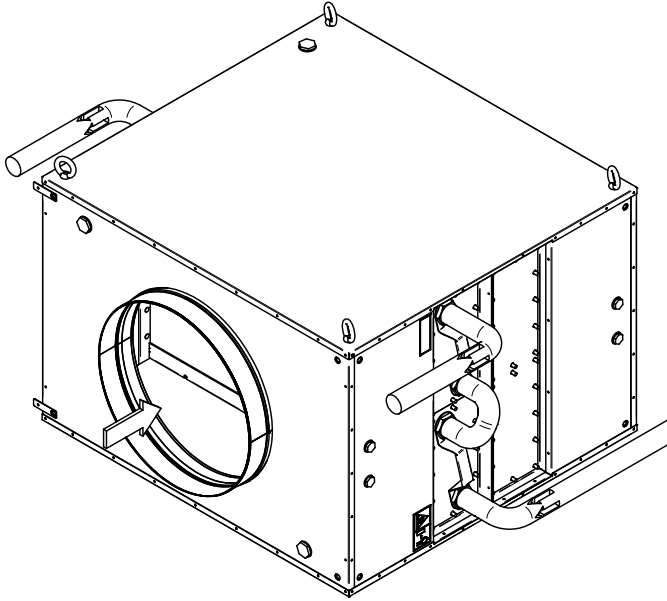

Water connection for BP750/1000-2

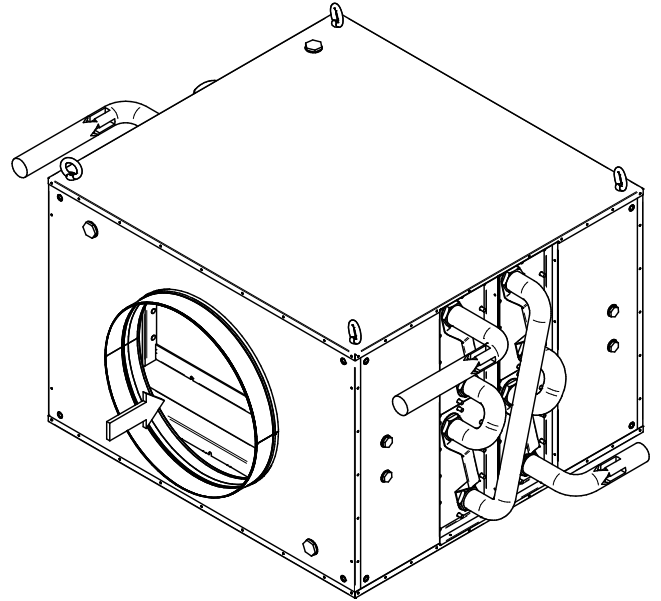

Water connection for BP2000

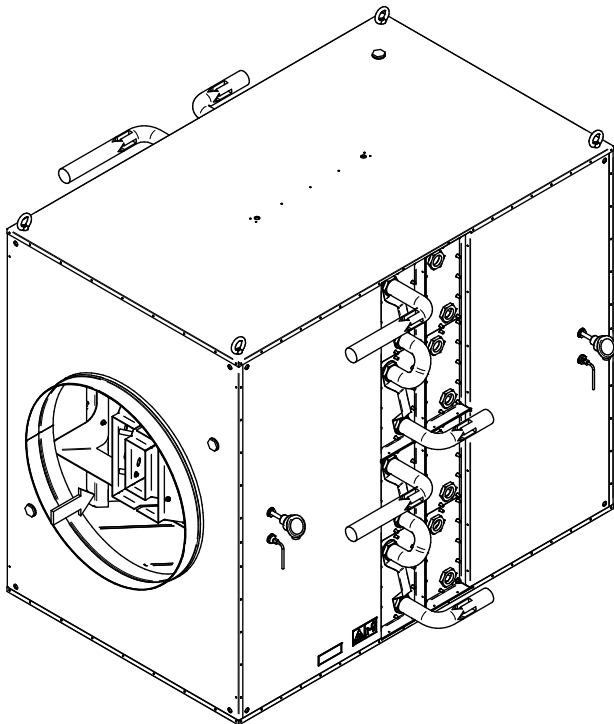

Water connection for BP2000-2

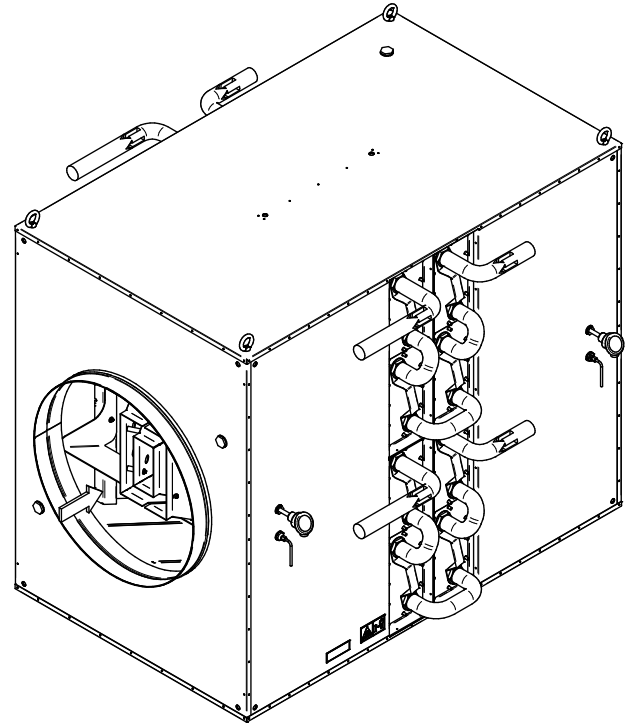

Installation without water connection

If Basic Plate is installed without water connection, the exchanger must be pulled out and a cover plate installed (if needed see section about Optional Components).

Tightening of the exchanger cover plate is done as shown in the illustration. Nuts are tightened crosswise to 20 Nm.

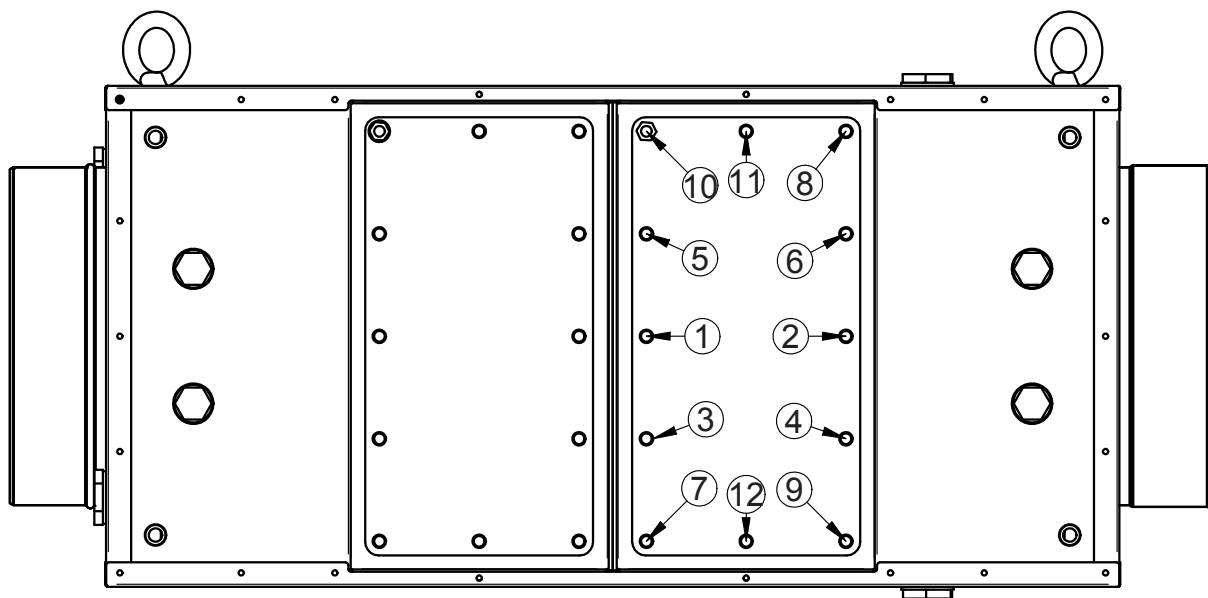

Electrical installation

Placement of Safety Thermostat



CAUTION! If using safety thermostat ST110, it must be placed away from the heat source, so the ambient temperature of the sensor is as low as possible. If this is not complied with, the heat recovery unit may be disabled inadvertently.

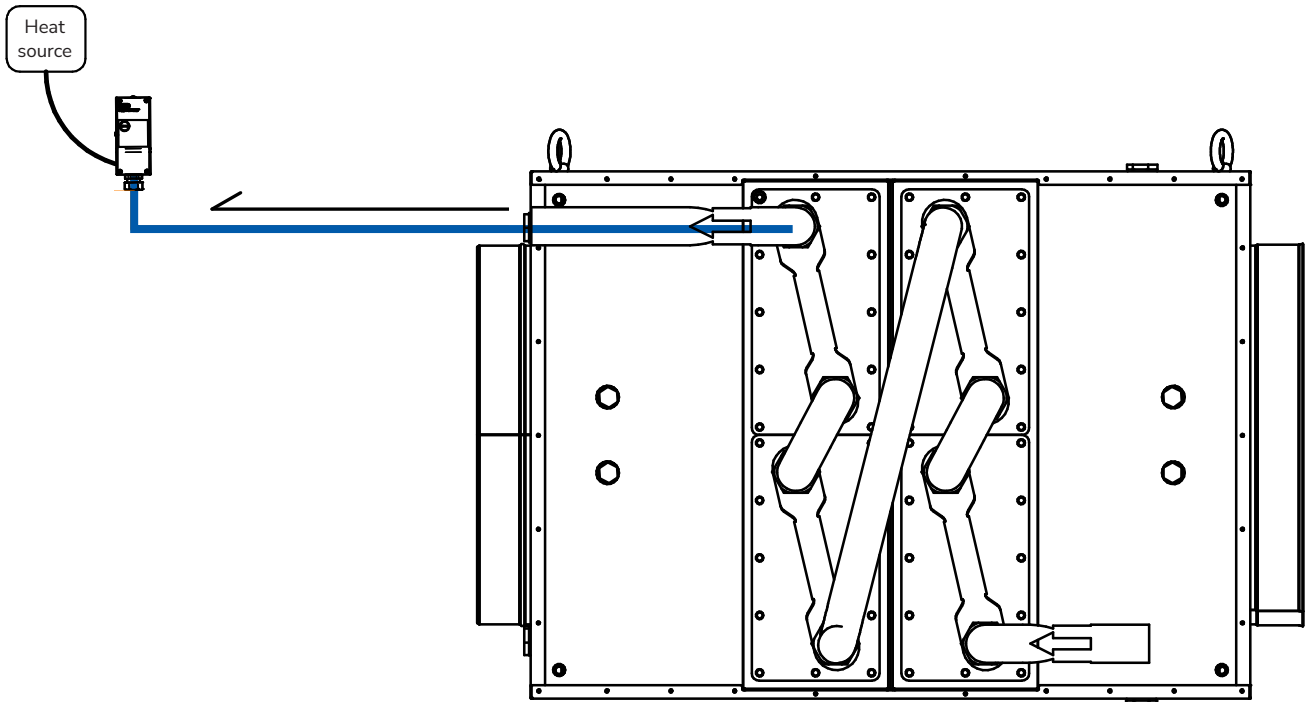

Operating conditions

Primary-/Flue Gas Side

- Max. flue gas temperature: 600°C
- Max. working pressure: 5000 Pa
- Min. working pressure: -5000 Pa
- Max. temperature on surface of heat exchanger: 190° (calculated in Opticalc)
- Flue gas quality: check that the flue gas is not corrosive for exchanger (option of other types of exchangers upon request)
- The chemical composition and pH of the condensate shall be checked before disposal

Secondary-/Liquid Side

- Max. working pressure: copper brazed heatexchanger 12 bar_a
- Min. working pressure: recommended system pressure 1.5 bar_a. See recommended system pressure in the section about System Pressure.
- Max. temperature on surface of heat exchanger: 190° (calculated in opticalc)
- Max. media temperature is dependent on the surface temperature and the used media

Startup and configuration

The purpose of this Exodraft Basic Plate heat recovery unit is to recover surplus energy from flue gasses and process air. The unit is environmentally friendly, economical, and compact.

System startup



CAUTION! Basic Plate should not be put into operation before being properly installed.

Danger of contact with hot components.

1. Connect the water and bleed the system
2. If condensation is a possibility, connect the drain to an appropriate outlet
3. Activate the circulation pump (not supplied by Exodraft) and check that it's running
4. Check that system pressure is consistent with system pressure tables in section about System pressure
5. Do a slow and controlled warmup of the Basic Plate water recovery unit
6. Check joints and connections for any leaking

Maintenance and troubleshooting

Care and cleaning



CAUTION! Basic Plate should be cleaned at regular intervals depending of the level of dirt in the passing air. The unit should be checked for leaks, corrosion, and wear at least once a year.

To ensure maximum flow through the exchanger cassettes, it is important to clean them. The cleaning interval will depend on how much dirt the unit is exposed to.

Cleaning of exchanger

1. Drain the water from the exchanger cassettes
2. Detach hose/pipe connections to exchanger
3. Loosen all nuts on the exchanger and pull the exchanger out by the handle
4. When cleaning the exchanger, you can use compressed air, soaking, or pressure washing
5. After cleaning, the exchanger is refitted. (Note that as a rule, the gasket can only be used once)
6. Nuts on the exchanger should be tightened crosswise to 20Nm
7. Reattach hose/pipe connections to exchanger
8. Follow directions from the point about Secondary-/Liquid Side as far as restarting the system



CAUTION! Use gloves and protective glasses when cleaning the exchanger.

Note: The exchangers are heavy – see weight table below.

Exodraft item number	Exchanger product number	Number of exchangers	Weight per exchanger [kg]
BP250	3200989	1	17,5
BP250-2	3200989	2	17,5
BP500	3200989	2	17,5
BP500-2	3200989	4	17,5
BP750	3200988	4	15
BP750-2	3200988	8	15
BP1000	3200989	4	17,5
BP1000-2	3200989	8	17,5
BP2000	3200989	8	17,5
BP2000-2	3200989	16	17,5

Troubleshooting

Observation	Problem	Solution
<i>The supply water temperature is low and the temperature difference between the flue gas intake and exhaust is too small</i>	There is air in the water system	The system needs to be bled
	The circulation pump is not operating correctly	Check the operation of the circulation pump
	The water flow is too fast	Check the operation of the circulation pump and mixing loop
	The mixing valve is not operating correctly	Check the operation of the controller
	The unit is in bypass mode	Check the motor voltage and connection
	The water connections have been switched	Correctly connect the supply and return sides (see section about connection)
	The exchanger cassette is blocked by debris	Clean the unit and check that the drain is working
<i>The Heat Recovery unit is in bypass mode, and the water temperature is low</i>	The flue gas temperature is lower than the setpoint, and the system goes into bypass mode	Check the operation of the safety thermostat Check the safety thermostat setting
	The safety thermostat is disengaging	The system needs to be bled Check the operation of the circulation pump
<i>The Heat Recovery unit is in bypass mode, and the water temperature is high</i>	The water temperature in the buffer tank has reached the maximum setpoint. The heat recovery switches to bypass mode	The system needs to be bled
	There is air in the water system	Check the operation of the circulation pump
	The circulation pump is not operating correctly	Check the operation of the controller
	The mixing valve is not operating correctly	A larger Basic Plate is needed or the burner power must be reduced
	The burner is operating at excessively high power	
<i>Poor chimney draft</i>	The exchanger cassette is dirty	Clean the unit and check that the drain is working

System pressure

System pressure is tested according to these standards:

2014/68/EU Fluid Group: 1 & 2 201, 2006/42/EF and 2014/35/EU

System pressure BP250 - 1. step

Minimum system pressure [bar _a]													
Exhaust temperature [°C]							Exhaust temperature [°C]						
Water sample temperature	Δt	200	300	400	500	600	Water sample temperature	Δt	200	300	400	500	600
	10	1,5	1,5	1,5	1,5	1,5		1,5	10	1,5	1,5	1,5	1,5
20	1,5	1,5	1,5	1,5	1,5	2,0	20	1,5	1,5	2	2,5	2,5	
60°C	30	1,5	1,5	2	2,5	3,5	70°C	30	1,5	2	2,5	3,5	4,5
	40	1,5	2	3	4	5,5		40	1,5	2,5	3	5	7
	50	1,5	2,5	3,5	6	8		50	2	3	4,5	6,5	10
Water sample temperature	Δt	200	300	400	500	600	Water sample temperature	Δt	200	300	400	500	600
	10	1,5	1,5	1,5	1,5	2		10	1,5	2	2	2	2,5
20	1,5	2	2,5	3	3,5		20	2	2,5	3	3,5	4,0	
80°C	30	2	3	4	4,5	5,5	90°C	30	2,5	4	5	5,5	6,5
	40	2,5	3,5	5	6,5	8		40	3	5	6,5	8	10
	50	2,5	4,5	6	8,5	12		50	3,5	5,5	8	11	NA
Water sample temperature	Δt	200	300	400	500	600	Water sample temperature	Δt	200	300	400	500	600
	10	2	2,5	2,5	3	3		10	2	2,5	3	3,5	4,0
20	2,5	3,5	4	5	5,0		20	2,5	3,5	4	5	5,0	
100°C	30	3,5	4,5	6	7	8	100°C	30	3,5	4,5	6	7	8
	40	4	6	8	10	12		40	4	6	8	10	12
	50	5	7	10	NA	NA		50	5	7	10	NA	NA

System pressure BP250 - 2. step

Minimum system pressure [bar _a]													
Exhaust temperature [°C]							Exhaust temperature [°C]						
Water sample temperature	Δt	200	300	400	500	600	Water sample temperature	Δt	200	300	400	500	600
	10	1,5	1,5	1,5	1,5	1,5		1,5	10	1,5	1,5	1,5	1,5
20	1,5	1,5	1,5	1,5	1,5	2,0	20	1,5	1,5	2	2,5	2,5	
60°C	30	1,5	1,5	1,5	2	2,5	70°C	30	1,5	2	2,5	3,5	3,5
	40	1,5	2	2	3	4		40	1,5	2,5	3	4	4,5
	50	1,5	2,5	2,5	3,5	5		50	1,5	3	3,5	4,5	6
Water sample temperature	Δt	200	300	400	500	600	Water sample temperature	Δt	200	300	400	500	600
	10	1,5	1,5	1,5	1,5	1,5		10	1,5	1,5	2	2	2
20	1,5	2	2	2,5	3,0		20	2	2,5	3	3,5	3,5	
80°C	30	2	2,5	3	4	4,5	90°C	30	2,5	3	4	4,5	5,5
	40	2	3	4	5	6,5		40	3	4	5	6,5	7,5
	50	2	3,5	4,5	6	8		50	3	4,5	6	8	10
Water sample temperature	Δt	200	300	400	500	600	Water sample temperature	Δt	200	300	400	500	600
	10	2	2,5	2,5	3	3		10	2	2,5	3	3,5	4,0
20	2,5	3	3,5	4	4,5		20	2,5	3	3,5	4	4,5	
100°C	30	3	4	5	6	7	100°C	30	3	4	5	6	7
	40	3,5	5	6,5	8	10		40	3,5	5	6,5	8	10
	50	4	6	8	10	12		50	4	6	8	10	12

System pressure BP500 - 1. step

Minimum system pressure [bar _a]													
Exhaust temperature [°C]							Exhaust temperature [°C]						
Water sample temperature	Δt	200	300	400	500	600	Water sample temperature	Δt	200	300	400	500	600
		10	1,5	1,5	1,5	1,5		1,5		10	1,5	1,5	1,5
	20	1,5	1,5	1,5	1,5	1,5		20	1,5	1,5	1,5	1,5	1,5
60°C	30	1,5	1,5	1,5	1,5	1,5	80°C	30	1,5	1,5	1,5	1,5	2
	40	1,5	1,5	1,5	1,5	2		40	1,5	1,5	2	2	2,5
	50	1,5	1,5	1,5	2	3		50	1,5	1,5	2	3	3,5
Water sample temperature	Δt	200	300	400	500	600	Water sample temperature	Δt	200	300	400	500	600
		10	1,5	1,5	1,5	1,5		1,5		10	1,5	1,5	1,5
	20	1,5	1,5	1,5	1,5	2,0		20	1,5	2	2	2	2,5
80°C	30	1,5	1,5	2	2	2,5	90°C	30	2	2	2,5	3	3
	40	1,5	2	2,5	3	3,5		40	2	2,5	3	3,5	4
	50	2	2,5	3	3,5	4,5		50	2	3	4	5	5,5
Water sample temperature	Δt	200	300	400	500	600	Water sample temperature	Δt	200	300	400	500	600
		10	1,5	2	2	2		2		10	1,5	2	2
	20	2	2,5	2,5	3	3,0		20	2	2,5	2,5	3	3,0
100°C	30	2,5	3	3,5	3,5	4		30	2,5	3	3,5	3,5	4
	40	2,5	3,5	4	4,5	5		40	2,5	3,5	4	4,5	5
	50	3	4	5	6	6,5		50	3	4	5	6	6,5

System pressure BP500 - 2. step

Minimum system pressure [bar _a]													
Exhaust temperature [°C]							Exhaust temperature [°C]						
Water sample temperature	Δt	200	300	400	500	600	Water sample temperature	Δt	200	300	400	500	600
		10	1,5	1,5	1,5	1,5		1,5		10	1,5	1,5	1,5
	20	1,5	1,5	1,5	1,5	1,5		20	1,5	1,5	1,5	1,5	1,5
60°C	30	1,5	1,5	1,5	1,5	1,5	70°C	30	1,5	1,5	1,5	1,5	1,5
	40	1,5	1,5	1,5	1,5	1,5		40	1,5	1,5	1,5	2	2
	50	1,5	1,5	1,5	1,5	2		50	1,5	1,5	1,5	2	2,5
Water sample temperature	Δt	200	300	400	500	600	Water sample temperature	Δt	200	300	400	500	600
		10	1,5	1,5	1,5	1,5		1,5		10	1,5	1,5	1,5
	20	1,5	1,5	1,5	1,5	1,5		20	1,5	1,5	2	2	2,0
80°C	30	1,5	1,5	1,5	2	2	90°C	30	1,5	2	2,5	2,5	3
	40	1,5	2	2	2,5	3		40	2	2,5	3	3	3,5
	50	1,5	2	2,5	3	3,5		50	2	2,5	3	3,5	4
Water sample temperature	Δt	200	300	400	500	600	Water sample temperature	Δt	200	300	400	500	600
		10	1,5	2	2	2		2		10	1,5	2	2
	20	2	2,5	2,5	2,5	3,0		20	2	2,5	2,5	3	3,0
100°C	30	2	2,5	3	3,5	3,5		30	2	2,5	3	3,5	3,5
	40	2,5	3	3,5	4,5	5		40	2,5	3	3,5	4,5	5
	50	2,5	3,5	4	5	5,5		50	2,5	3,5	4	5	5,5

System pressure BP750 - 1. step

Minimum system pressure [bar _a]													
Exhaust temperature [°C]							Exhaust temperature [°C]						
Water sample temperature	Δt	200	300	400	500	600	Water sample temperature	Δt	200	300	400	500	600
	10	1,5	1,5	1,5	1,5	1,5		1,5	10	1,5	1,5	1,5	1,5
20	1,5	1,5	1,5	1,5	1,5	1,5	20	1,5	1,5	1,5	1,5	1,5	1,5
60°C	30	1,5	1,5	1,5	1,5	1,5	80°C	30	1,5	1,5	1,5	1,5	2
	40	1,5	1,5	1,5	1,5	2		40	1,5	1,5	2	2	2,5
	50	1,5	1,5	1,5	2	3		50	1,5	1,5	2,5	3	3,5
Water sample temperature	Δt	200	300	400	500	600	Water sample temperature	Δt	200	300	400	500	600
	10	1,5	1,5	1,5	1,5	1,5		10	1,5	1,5	1,5	1,5	1,5
20	1,5	1,5	1,5	1,5	1,5	2,0	20	1,5	2	2	2	2	2,5
80°C	30	1,5	1,5	2	2	2,5	90°C	30	2	2	2,5	3	3
	40	1,5	2	2,5	3	3,5		40	2	2,5	3	3,5	4
	50	2	2,5	3	3,5	4,5		50	2,5	3	4	5	5,5
Water sample temperature	Δt	200	300	400	500	600	Water sample temperature	Δt	200	300	400	500	600
	10	1,5	2	2	2	2		10	1,5	2	2	2	2
20	2	2,5	2,5	3	3,0	20	2	2,5	2,5	3	3	3	
100°C	30	2,5	3	3,5	3,5	4	100°C	30	2,5	3	3,5	3,5	4
	40	2,5	3,5	4	4,5	5		40	2,5	3,5	4	4,5	5
	50	3	4	5	6	6,5		50	3	4	5	6	6,5

System pressure BP750 - 2. step

Minimum system pressure [bar _a]													
Exhaust temperature [°C]							Exhaust temperature [°C]						
Water sample temperature	Δt	200	300	400	500	600	Water sample temperature	Δt	200	300	400	500	600
	10	1,5	1,5	1,5	1,5	1,5		1,5	10	1,5	1,5	1,5	1,5
20	1,5	1,5	1,5	1,5	1,5	1,5	20	1,5	1,5	1,5	1,5	1,5	1,5
60°C	30	1,5	1,5	1,5	1,5	1,5	70°C	30	1,5	1,5	1,5	1,5	1,5
	40	1,5	1,5	1,5	1,5	1,5		40	1,5	1,5	1,5	2	2
	50	1,5	1,5	1,5	1,5	2		50	1,5	1,5	1,5	2	2,5
Water sample temperature	Δt	200	300	400	500	600	Water sample temperature	Δt	200	300	400	500	600
	10	1,5	1,5	1,5	1,5	1,5		10	1,5	1,5	1,5	1,5	1,5
20	1,5	1,5	1,5	1,5	1,5	2,0	20	1,5	1,5	2	2	2	2,0
80°C	30	1,5	1,5	1,5	2	2	90°C	30	1,5	2	2,5	2,5	3
	40	1,5	2	2	2,5	3		40	2	2,5	3	3	3,5
	50	1,5	2	2,5	3	3,5		50	2	2,5	3	3,5	4,5
Water sample temperature	Δt	200	300	400	500	600	Water sample temperature	Δt	200	300	400	500	600
	10	1,5	2	2	2	2		10	1,5	2	2	2	2
20	2	2,5	2,5	2,5	3,0	20	2	2,5	2,5	3	3	3	
100°C	30	2	2,5	3	3,5	3,5	100°C	30	2	2,5	3	3,5	3,5
	40	2,5	3	3,5	4,5	5		40	2,5	3	3,5	4,5	5
	50	2,5	3,5	4	5	5,5		50	2,5	3,5	4	5	5,5

System pressure BP1000 - 1. step

Minimum system pressure [bar _a]													
Exhaust temperature [°C]							Exhaust temperature [°C]						
Water sample temperature	Δt	200	300	400	500	600	Water sample temperature	Δt	200	300	400	500	600
	10	1,5	1,5	1,5	1,5	1,5		1,5	10	1,5	1,5	1,5	1,5
60°C	20	1,5	1,5	1,5	1,5	1,5	70°C	20	1,5	1,5	1,5	1,5	1,5
	30	1,5	1,5	1,5	1,5	1,5		30	1,5	1,5	1,5	1,5	2
	40	1,5	1,5	1,5	1,5	2		40	1,5	1,5	2	2	2,5
	50	1,5	1,5	1,5	2	3		50	1,5	1,5	2,5	3	3,5
Water sample temperature	Δt	200	300	400	500	600	Water sample temperature	Δt	200	300	400	500	600
	10	1,5	1,5	1,5	1,5	1,5		10	1,5	1,5	1,5	1,5	1,5
80°C	20	1,5	1,5	1,5	1,5	2,0	90°C	20	1,5	2	2	2	2,5
	30	1,5	1,5	2	2	2,5		30	2	2	2,5	3	3
	40	1,5	2	2,5	3	3,5		40	2	2,5	3	3,5	4
	50	2	2,5	3	3,5	4,5		50	2	3	4	5	5,5
Water sample temperature	Δt	200	300	400	500	600	Water sample temperature	Δt	200	300	400	500	600
	10	1,5	2	2	2	2		10	1,5	2	2	2	2
100°C	20	2	2,5	2,5	3	3,0	100°C	20	2,5	3	3,5	3,5	4
	30	2,5	3	3,5	3,5	4		30	2,5	3,5	4	4,5	5
	40	3	4	5	6	6,5		40	3	4	5	6	6,5

System pressure BP1000 - 2. step

Minimum system pressure [bar _a]													
Exhaust temperature [°C]							Exhaust temperature [°C]						
Water sample temperature	Δt	200	300	400	500	600	Water sample temperature	Δt	200	300	400	500	600
	10	1,5	1,5	1,5	1,5	1,5		1,5	10	1,5	1,5	1,5	1,5
60°C	20	1,5	1,5	1,5	1,5	1,5	70°C	20	1,5	1,5	1,5	1,5	1,5
	30	1,5	1,5	1,5	1,5	1,5		30	1,5	1,5	1,5	1,5	1,5
	40	1,5	1,5	1,5	1,5	1,5		40	1,5	1,5	1,5	2	2
	50	1,5	1,5	1,5	1,5	2		50	1,5	1,5	1,5	2	2,5
Water sample temperature	Δt	200	300	400	500	600	Water sample temperature	Δt	200	300	400	500	600
	10	1,5	1,5	1,5	1,5	1,5		10	1,5	1,5	1,5	1,5	1,5
80°C	20	1,5	1,5	1,5	1,5	2,0	90°C	20	1,5	1,5	2	2	2,0
	30	1,5	1,5	1,5	2	2		30	1,5	2	2,5	2,5	2,5
	40	1,5	2	2	2,5	3		40	2	2,5	3	3	3,5
	50	1,5	2	2,5	3	3,5		50	2	2,5	3	3,5	4
Water sample temperature	Δt	200	300	400	500	600	Water sample temperature	Δt	200	300	400	500	600
	10	1,5	2	2	2	2		10	1,5	2	2	2	2
100°C	20	2	2,5	2,5	2,5	2,5	100°C	20	2,5	3	3,5	3,5	4
	30	2	2,5	3	3,5	4		30	2,5	3	3,5	4,5	5
	40	2,5	3,5	4	5	5,5		40	2,5	3,5	4	5	5,5

System pressure BP2000 - 1. step

Minimum system pressure [bar _a]													
Exhaust temperature [°C]							Exhaust temperature [°C]						
Water sample temperature	Δt	200	300	400	500	600	Water sample temperature	Δt	200	300	400	500	600
	10	1,5	1,5	1,5	1,5	1,5		1,5	10	1,5	1,5	1,5	1,5
60°C	20	1,5	1,5	1,5	1,5	1,5	70°C	20	1,5	1,5	1,5	1,5	1,5
	30	1,5	1,5	1,5	1,5	1,5		30	1,5	1,5	1,5	1,5	2
	40	1,5	1,5	1,5	1,5	2		40	1,5	1,5	2	2	2,5
	50	1,5	1,5	1,5	2	3		50	1,5	1,5	2,5	3	3,5
Water sample temperature	Δt	200	300	400	500	600	Water sample temperature	Δt	200	300	400	500	600
	10	1,5	1,5	1,5	1,5	1,5		10	1,5	1,5	1,5	1,5	1,5
80°C	20	1,5	1,5	1,5	1,5	2,0	90°C	20	1,5	2	2	2	2,5
	30	1,5	1,5	2	2	2,5		30	2	2	2,5	3	3
	40	1,5	2	2,5	3	3,5		40	2	2,5	3	3,5	4
	50	2	2,5	3	3,5	4,5		50	2	3	4	5	5,5
Water sample temperature	Δt	200	300	400	500	600	Water sample temperature	Δt	200	300	400	500	600
	10	1,5	2	2	2	2		10	1,5	2	2	2	2
100°C	20	2	2,5	2,5	3	3,0	100°C	20	2,5	3	3,5	3,5	4
	30	2,5	3	3,5	3,5	4		30	2,5	3,5	4	4,5	5
	40	3	4	5	6	6,5		40	3	4	5	6	6,5

System pressure BP2000 - 2. step

Minimum system pressure [bar _a]													
Exhaust temperature [°C]							Exhaust temperature [°C]						
Water sample temperature	Δt	200	300	400	500	600	Water sample temperature	Δt	200	300	400	500	600
	10	1,5	1,5	1,5	1,5	1,5		1,5	10	1,5	1,5	1,5	1,5
60°C	20	1,5	1,5	1,5	1,5	1,5	70°C	20	1,5	1,5	1,5	1,5	1,5
	30	1,5	1,5	1,5	1,5	1,5		30	1,5	1,5	1,5	1,5	1,5
	40	1,5	1,5	1,5	1,5	1,5		40	1,5	1,5	1,5	2	2
	50	1,5	1,5	1,5	1,5	2		50	1,5	1,5	1,5	2	2,5
Water sample temperature	Δt	200	300	400	500	600	Water sample temperature	Δt	200	300	400	500	600
	10	1,5	1,5	1,5	1,5	1,5		10	1,5	1,5	1,5	1,5	1,5
80°C	20	1,5	1,5	1,5	1,5	2,0	90°C	20	1,5	1,5	2	2	2,0
	30	1,5	1,5	1,5	2	2		30	1,5	2	2,5	2,5	2,5
	40	1,5	2	2	2,5	3		40	2	2,5	3	3	3,5
	50	1,5	2	2,5	3	3,5		50	2	2,5	3	3,5	4
Water sample temperature	Δt	200	300	400	500	600	Water sample temperature	Δt	200	300	400	500	600
	10	1,5	2	2	2	2		10	1,5	2	2	2	2
100°C	20	2	2,5	2,5	2,5	2,5	100°C	20	2,5	3	3,5	3,5	4
	30	2,5	3	3,5	4,5	5		30	2,5	3,5	4	5	5,5
	40	3	4	5	6	6,5		40	3	4	5	6	6,5



UK Conformity Assessed



**Exodraft a/s
Industrivej 10
DK-5550 Langeskov**

Hereby declares that the following products:

BP250, BP250-2, BP500, BP500-2, BP750,
BP750-2, BP1000, BP1000-2, BP2000, BP2000-2

Were manufactured in conformity with the provisions of the following regulations:

The Supply of Machinery (Safety) Regulations 2008

Electrical Equipment (Safety) Regulations 2016

Electromagnetic Compatibility Regulations 2016

Langeskov, 15-01-2025
Managing Director
Anders Haugaard



Declaration of Conformity

DK: EU-Overensstemmelseserklæring
 GB: Declaration of Conformity
 DE: EU-Konformitätserklärung
 FR: Déclaration de conformité de l'Union Européenne
 NO: EU-Samsvarserklæring
 PL: EU Deklaracja zgodności

NL: EU-Conformiteits verklaring
 SE: EU-Överensstämmelsedeklaration
 FI: EU-Vaatimustenmukaisuusvakuutus
 IS: ESS-Samræmisstaðfesting
 IT: Dichiarazione di Conformità Unione Europea

exodraft

Exodraft a/s
Industrivej 10
DK-5550 Langeskov

Erklærer på eget ansvar, at følgende produkter:
 Hereby declares that the following products:
 Erklärt hierdurch auf eigene Verantwortung, daß folgende Produkte:
 Déclare, sous sa propre responsabilité, que les produits suivants:
 Erklærer på eget ansvar at følgende produkter:
 Niniejszym oświadczam, że następujące produkty:

Veklaart dat onderstaande producten:
 Deklarerar på eget ansvar, att följande produkter:
 Vastaa siltä, että seuraava tuote:
 Staðfesti à eigin àbyrgð, að eftirfarandi vörur:
 Dichiaro con la presente che i seguenti prodotti:

BP250, BP250-2, BP500, BP500-2, BP750,
 BP750-2, BP1000, BP1000-2, BP2000, BP2000-2

Som er omfattet af denne erklæring, er i overensstemmelse med følgende standarder:
 Were manufactured in conformity with the provisions of the following standards:
 Die von dieser Erklärung umfaßt sind, den folgenden Normen:
 Auxquels s'applique cette déclaration sont en conformité avec les normes ci-contre:
 Som er omfattet av denne erklæring, er i samsvar med følgende standarder:
 Zostały wyprodukowane zgodnie z warunkami określonymi w następujących normach:

Zijn vervaardigd in overeenstemming met de voorschriften uit de hieronder genoemde normen en standaards:
 Som omfattas av denna deklaration, överensstämmer med följande standarder:
 Jota tämä selvitys koskee, on seuraavien standardien mukainen:
 Sem eru meðtalin í staðfestingu Pessari, eru í fullu samræmi við eftirtalda staðla:
 Sono stati fabbricati in conformità con le norme degli standard seguenti:

EN 60335-1, EN 60335-2-80, DS/EN ISO 12100: 2011

I.h.t bestemmelser i direktiv:
 In accordance with
 Entsprechen gemäß den Bestimmungen der folgenden Richtlinien:
 Suivant les dispositions prévues aux directives:
 I.h.t bestemmelser i direktiv:
 Zgodnie z:

En voldoen aan de volgende richtlijnen:
 Enligt bestämmelserna i följande direktiv:
 Seuraavien direktiivien määräysten mukaan:
 Med tilvisun til ákvarðana eftirlits:
 In conformità con le direttive:

Maskindirektivet:
 The Machinery Directive:
 Richtlinie Maschinen:
 Directive Machines:
 Maskindirektivet:
 Dyrektywę maszynową:

De machinerichtlijn:
 Maskindirektivet
 Konedirektiivi:
 Vèlaeftirlitið:
 Direttiva Macchinari:

2006/42/EF-EEC/-EWG/-CEE

Lavspændingsdirektiv:
 The Low Voltage Directive:
 Niederspannungsrichtlinie:
 Directive Basse Tension:
 Lavspenningsdirektivet:
 Dyrektywę Niskonapięciową

De laagspanningsrichtlijn:
 Lågspänningsdirektivet:
 Pienjännitedirektiivi:
 Smáspennueftirlitið:
 Direttiva Basso Voltaggio:

2014/35/EC

EMC-direktivet:
 And the EMC Directive:
 EMV-Richtlinie:
 Directive Compatibilité Electromagnétique:
 EMC-direktivet:
 Dyrektywę EMC – kompatybilności elektromagnetycznej

En de EMC richtlijn:
 EMC-direktivet:
 EMC-direktiivi:
 EMC-efirlitið:
 Direttiva Compatibilità Elettromagnetica:

2014/30/EC

Langeskov, 15-01-2025
 Adm. direktør
 Managing Director
 Anders Haugaard

Algemeen directeur
 Geschäftsführender Direktor
 Président Directeur Général
 Verkställande direktör
 Toimitusjohtaja
 Framkvemdastjóri
 Direttore Generale

DK: Exodraft a/s

Industrivej 10
DK-5550 Langeskov
Tel: +45 7010 2234
Fax: +45 7010 2235
info@exodraft.dk
www.exodraft.dk

SE: Exodraft a/s

Valhallavägen 9A
SE-375 30 Mörrum
Tel: +46 (0)8-5000 1520
info@exodraft.se
www.exodraft.se

NO: Exodraft a/s

Storgaten 88
NO-3060 Svelvik
Tel: +47 3329 7062
info@exodraft.no
www.exodraft.no

UK: Exodraft Ltd.

24 Janes Meadow, Tarleton
GB-Preston PR4 6ND
Tel: +44 (0)1494 465 166
Fax: +44 (0)1494 465 163
info@exodraft.co.uk
www.exodraft.co.uk

DE: Exodraft a/s

Niederlassung Deutschland
Industriestraße 14
DE-55768 Hoppstädten-Weiersbach
Tel: +49 6782 989 590
Fax: +49 6782 989 5929
info@exodraft.de
www.exodraft.de

FR: Exodraft sas

78, rue Paul Jozon
FR-77300 Fontainebleau
Tel: +33 (0)6 3852 3860
info@exodraft.fr
www.exodraft.fr

Your energy. Optimized.

exodraft