

Chimney Fan

RHG

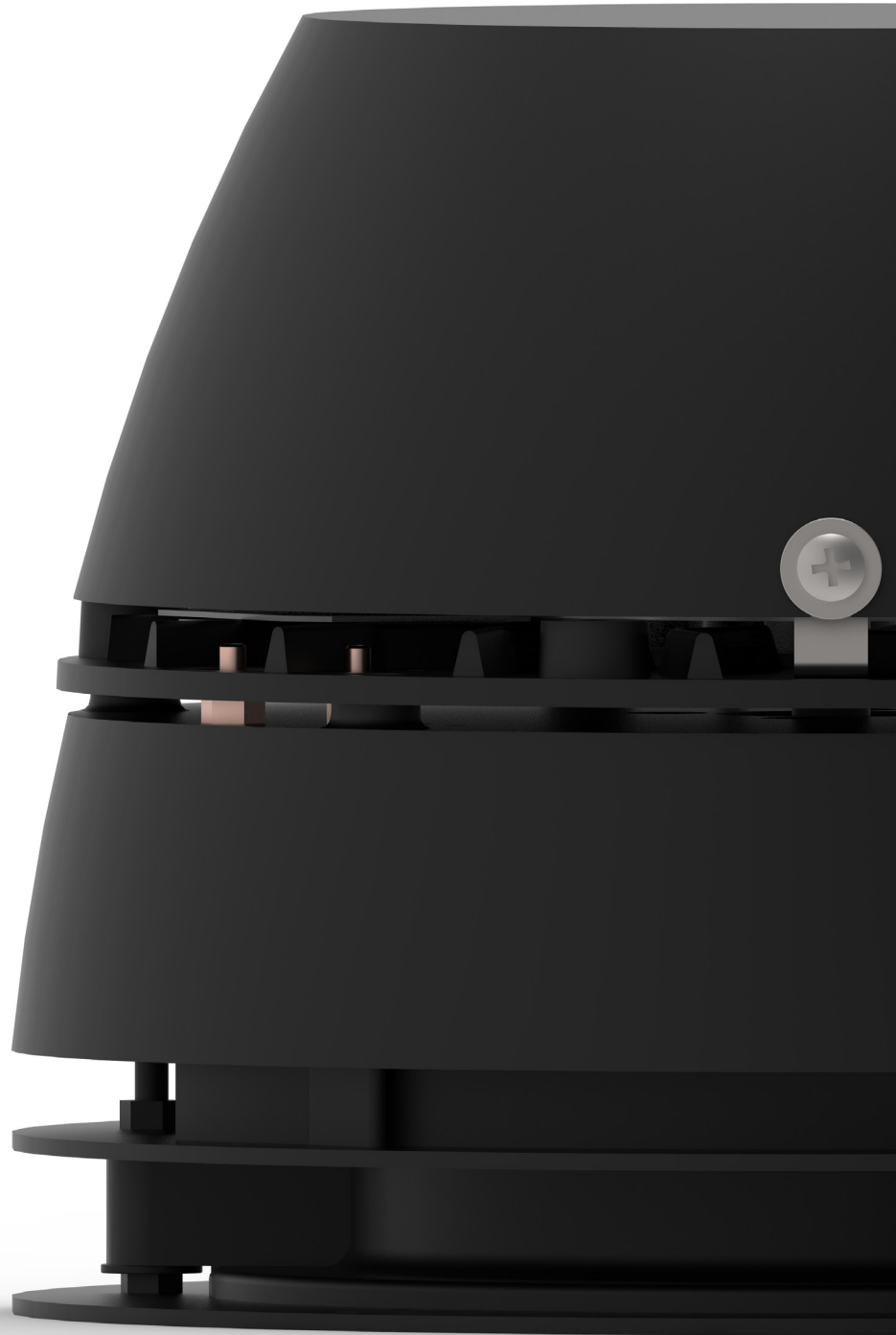

UK | Read and save these instructions!

exodraft
Your energy. Optimized.

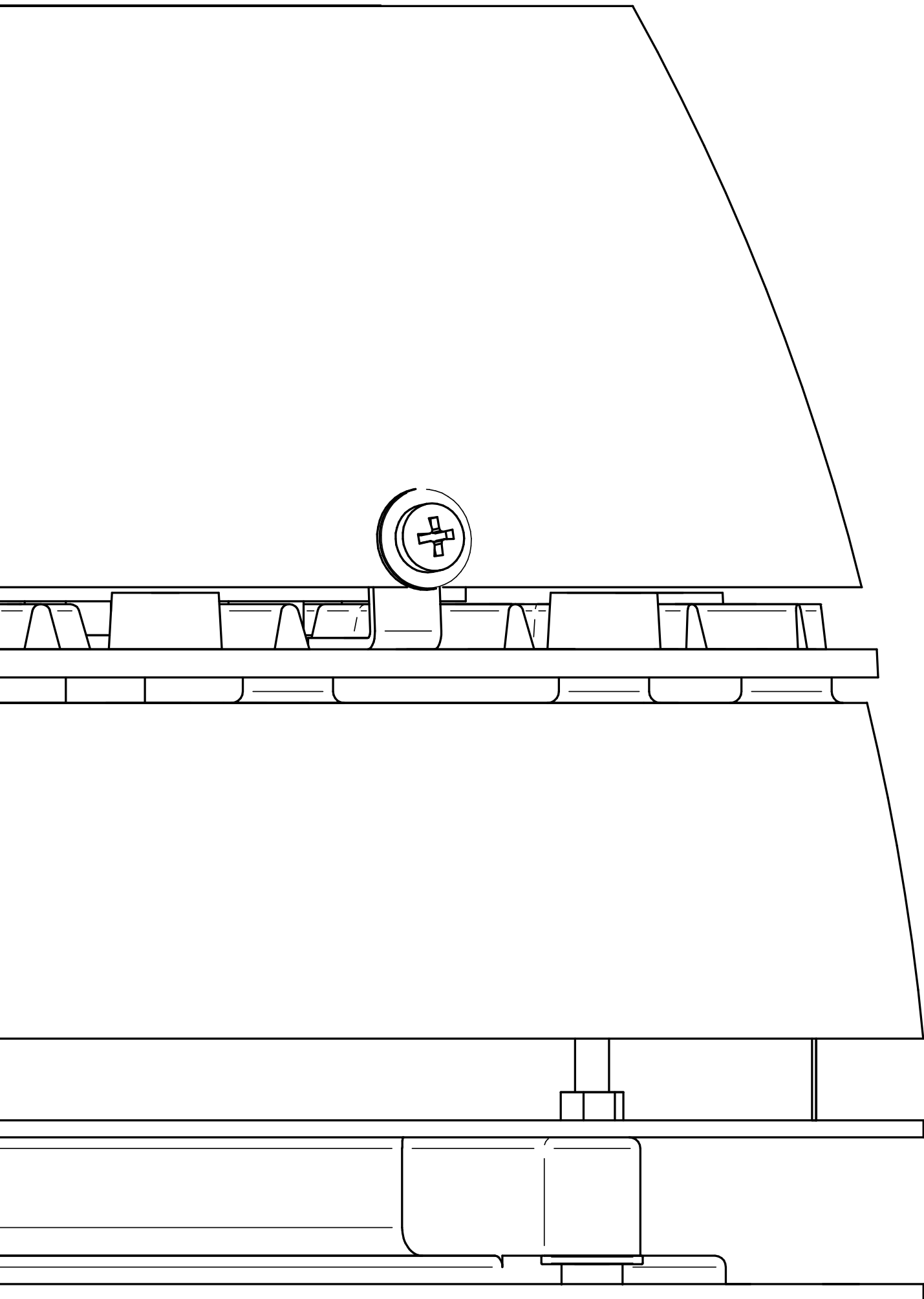

Chimney Fan | RHG

Content

Product information	7
Scope of supply	7
Accessories and spare parts	7
Warranty	8
Technical specifications	8
Precautions and user instructions	11
Mechanical installation	12
Positioning of the chimney fan	12
Minimum distance	12
Installation onto a brick chimney	13
Installation onto a steel chimney	15
Multiple fans on chimney	17
Electrical installation	18
Isolation switch	18
Startup and configuration	19
System testing	19
Operating the fireplace using the EFC21 controller	19
Testing flue gas extraction and the pressure switch setting	20
Maintenance and troubleshooting	21
Care and cleaning	21
Troubleshooting	22
UK Conformity Assessed	23
Declaration of Conformity	24



How to use this manual

This manual has been prepared based on the specific product and contains relevant technical information and installations guides.

Accessories and spare parts are not covered by this manual. Please refer to the individual manuals of these components.

This installation manual does not contain any system design documentation.

Failure to observe instructions marked with a danger symbol may result in personal injury and/or damage to the product.

Errors and omissions excepted.



Disposal

Electrical and electronic equipment (EEE) often contain materials, components and substances that may harm the environment or be hazardous to your health. Products (WEEE) marked with the 'crossed-out wheeled bin' symbol should be disposed of separately from other waste at the end of its life. Though legislation may differ from country to country we strongly advise that electrical and electronic waste is separated from other waste and disposed of according to national legislation to protect the environment and personnel that may come into contact with waste.

Symbols

The following symbols may be used in the manual to draw attention to danger or risk of personal injury or damage to the product.



General prohibition

Failure to observe instructions marked with the prohibited symbol may result in extreme danger or serious personal injury.



General attention

Marks a dangerous situation that, in the worst-case scenario, can cause serious personal injury or significant damage to the product.



General warning

Failure to observe instructions marked with a danger symbol may result in personal injury and/or damage to the product.



Electricity hazard/High Voltage

Marks a situation in which caution is advised due to the risk of high voltage electric shock which can cause serious personal injury or significant damage to the product.



Connect an earth terminal to the ground

Failure to observe instructions marked with a danger symbol may result in personal injury and/or damage to the product.



Permitted and approved

Permitted and approved method of installation.



Prohibited and not approved

Prohibited and not approved method of installation.



Warning

To minimise the risk of fire, electric shock, personal injury and/or damage to the product please observe the following:

- Please read the manual before you start using the product and only use the product in accordance with the manufacturer's instructions. If in doubt, contact one of our specialized dealers.
- All installations must be carried out by properly qualified personnel and in accordance with national legislation and regulations.
- This product must be earthed. Get assistance from a qualified electrician if in doubt.
- In order to avoid chimney fires, ensure that the chimney has been swept before mounting the fan.
- The chimney fan must remain switched on the entire time when the fireplace is in use.
- Exodraft recommends that the chimney fan is switched on at least once every three months, to avoid longer periods of stagnation as this may have a negative effect on the mechanical parts.
- Prior to servicing the product, disconnect the power and ensure that it cannot accidentally be reconnected.
- Exodraft always recommends the use of a smoke alarm when a solid fuel fireplace is installed.
- If the Exodraft fan system has been designed for solid fuel/multi fuel installations, please ensure that the design meets the requirements of BS EN15287-1. If this cannot be achieved, a smoke alarm must be installed in the same room as the heat appliance.
- Note! Fans serving biomass boilers must be cleaned more often due to extensive residue/soot building. It is essential that a regular inspection and cleaning schedule is implemented, especially in the early days of usage, to experience how often regular inspections and cleaning should be carried out.

Product information

An Exodraft RHG chimney fan is designed with horizontal discharge.

The fan must be installed on top of a chimney and creates a negative pressure (suction) along the full length of the flue.

The fan is developed specifically for open gas fireplaces with a max. gas supply of 12.0 kW (40,900 Btu/h). For higher gas supply values, please contact Exodraft.

The fan is part of an Exodraft system and should be connected to an EFC21 Exodraft controller for optimal effect.

Please check out this site for advice about other Exodraft products:

www.exodraft.com

Scope of supply

- Exodraft RHG chimney fan
- Mineral wool mat for vibration-free mounting
- Packet with location brackets and nuts
- Installation manual and user instructions
- Armoured hose

Accessories and spare parts

The table below shows the accessories and spare parts available for the RHG-models.

Accessories*	Spare parts
Flanges (for steel chimneys)	Motors
RSD - Dilution bolts (for brick chimneys)	Impellers
	Capacitors
	Mineral wool mats
	SVD-RS - Vibrations dampers (for flanges on steel chimneys)
	PDS - Pressure differential switch

*This manual does not describe the specific use of accessories. We refer to the separate manuals for such components.

For more details contact your Exodraft dealer.

Warranty

All Exodraft products are covered by a 2-year guarantee as per European consumer rights legislation. For some countries an extended period of guarantee may apply depending on either national legislation or other clearly stipulated conditions. Customer complaints must be handled by a specialised dealer or wholesaler (preferably where the Exodraft product has been bought originally). An updated list of Exodraft specialised dealers can be found on our website for the country in question.

Exodraft products must always be installed by properly qualified personnel. Exodraft reserves the right to change these guidelines without prior notice.

The warranty and liability does not cover instances regarding personal injury or damage to property or the product that can be ascribed to one or more of the following causes:

- Failure to follow this installation and operation manual
- Incorrect installation, start-up, maintenance or servicing
- Improper repairs
- Unauthorised structural modifications made to the product
- Installation of additional components that have not been tested/approved with the product
- Any damage resulting from continued use of the product despite an evident defect
- Failure to use original spareparts and accessories
- Failure to use the product as intended
- Exceeding or failure to meet the limit values in the technical data
- Force majeure

Technical specifications

The RHG fan is designed for horizontal discharge. It is available in one size.

This chimney fan is made of cast aluminium with a forwards-curved centrifugal impeller made of galvanised steel.

Chimney fan	Centrifugal impeller
RHG160-41	Galvanised steel impeller

The chimney fan can be opened for service and cleaning purposes.

The chimney fan has a built-in fail-safe system consisting of a pressure differential switch (PDS) and two pressure sensors, ensuring correct airflow when the fire is used.

The sound level varies between the different chimney fan models.
Further information about sound levels available in our technical brochure/datasheet.

The RHG chimney fan is designed to operate with a maximum flue gas temperature of 200 °C.

The run capacitor is considered a wear part and will need to be replaced depending on usage.

Technical data

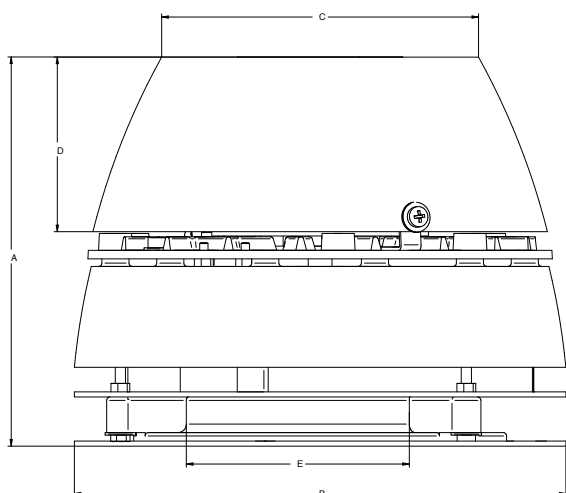

Model	Motor specifications				Weight kg	Dimension [mm]				
	rpm	V	Amp	kW*		A	B [Ø]	C	D	E [Ø]
RHG160-41	1400	1 x 230	0.40	0.09	10	230	290	187	103	142

*Power consumption at ambient temperature of 20 °C

- The RPM of the above fan models are infinitely adjustable
- The motor is overload protected
- Motor protection IP rating IP54
- Insulation class F

Construction and components

1	Top section
2	Base plate
3	Motor
4	Cooling plate
5	Pressure differential switch (PDS)
6	Pressure sensors
7	Impeller
8	Bottom section
9	Guide vanes
10	Inlet ring
11	Armoured cable and connecting cable
12	Mineral wool mat
13	Location brackets, bolts and nuts etc.

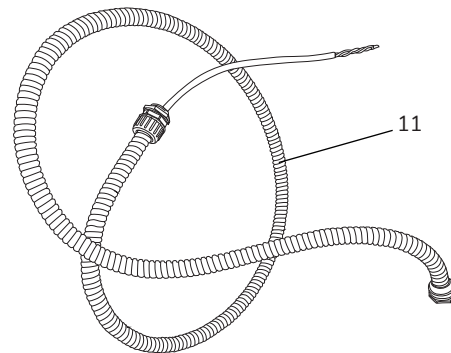
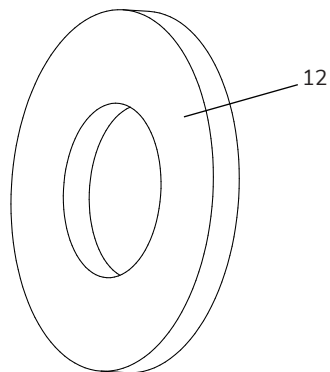
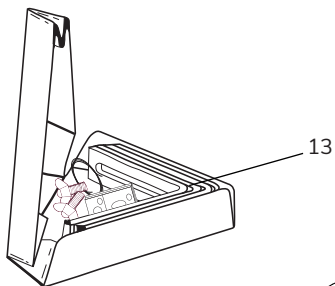
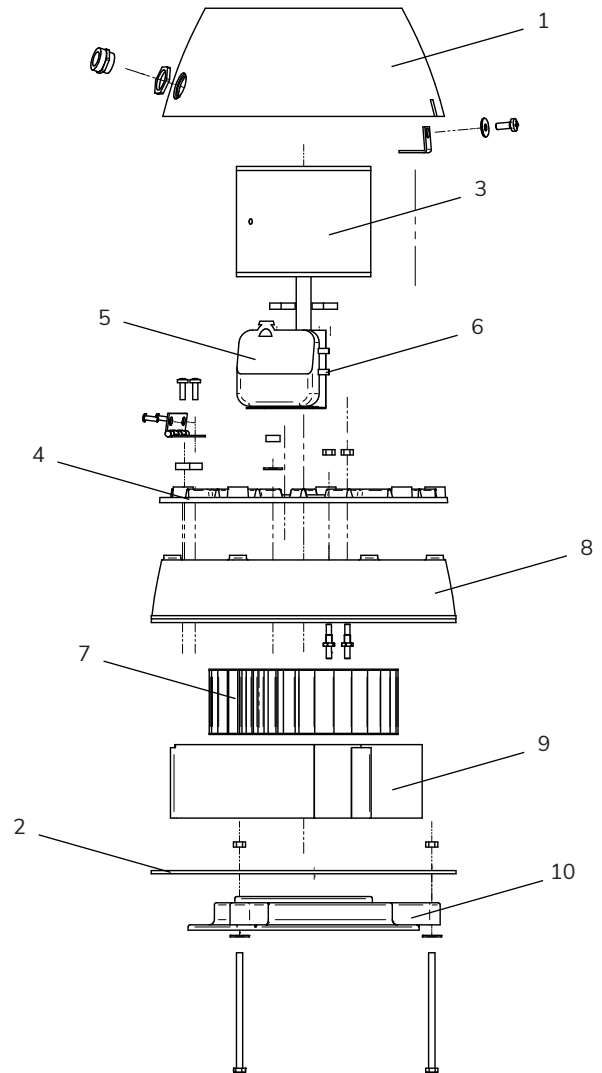

Precautions and user instructions

These instructions, applicable standards and relevant safety procedures from the manufacturer must be followed and at the same time the official provisions in force in the country, where the product is installed, must be observed.

Support system

Prior to installation of a chimney fan, it must be determined if the chimney can safely carry the weight of the chimney fan.

A steel chimney should be well supported at the roof penetration point. If the chimney extends high above the roof, the chimney and the fan should be secured. The manufacturer's instructions must be followed.

Brick chimneys do not usually need any kind of support to carry the weight of the chimney fan.

System type

Gas fireplaces and individual gas-fired boilers used in private dwellings normally operate in a relatively stable environment, where no major pressure fluctuations occur. However, to secure an optimal use of the Exodraft system speed adjustments and adjustment of air intakes are required depending on the weather outside and on the stage of the firing process.

Gas fireplaces and individual gas-fired boilers used in restaurants are exposed to major pressure changes due to factors like the constant opening/closing of doors, kitchen exhaust fans pulling out air, etc. In an environment like this spillage of smoke can easily occur.

The fan must be connected to an Exodraft control type EFC21.

Precautions

Be aware

- that it must be installed on top of the chimney
- that it can be mounted on steel as well as brick chimneys
- that it must be mounted with the approved Exodraft accessories
- that the chimney fan must always remain switched on when the fireplace is in use
- that it must be accessible for service and maintenance from the roof or from a ladder/cherry picker
- that the distance to flammable materials must be at least 500 mm
- that the isolation switch must be easily accessible



ATTENTION! It is always recommended to install a smoke alarm in connection with a gas-fired installation.

Mechanical installation

Exodraft products must always be installed by properly qualified personnel and according to the manufacturer's instructions.

Gas appliances should be checked for safety once a year by a installer registered in the Gas Safe Register. Details of local installers can be obtained by accessing the website at www.gassaferegister.co.uk

Positioning of the chimney fan

The chimney fan can be mounted horizontally or vertically. Be aware of national law and building regulations!

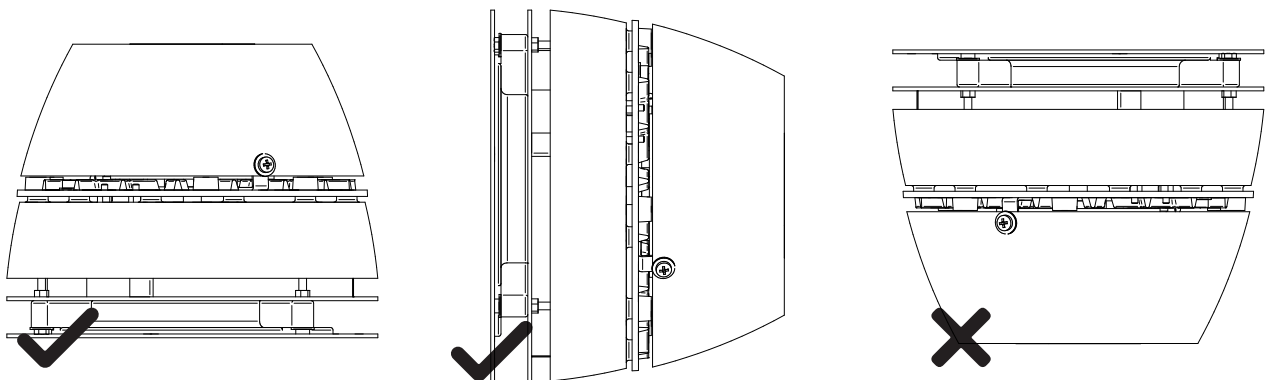

Minimum distance

The minimum distance to flammable materials must be at least 500 mm (national legislation must be observed)!

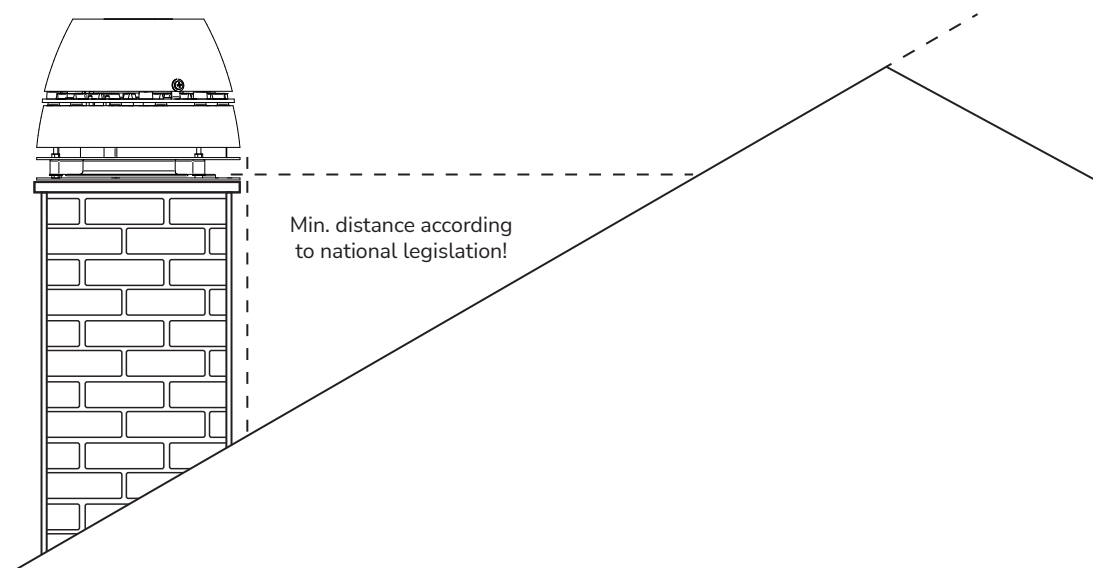

Installation onto a brick chimney

If the fan is to be fitted on a brick chimney, please use the location brackets. See the installation guide below.

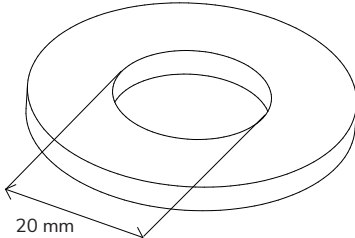
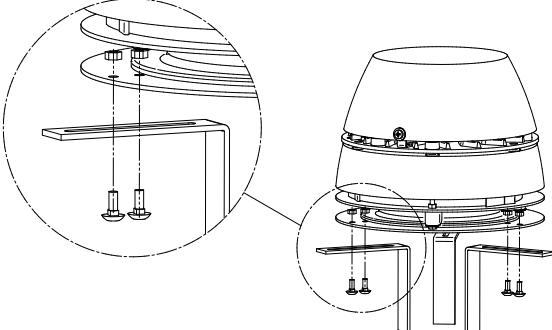
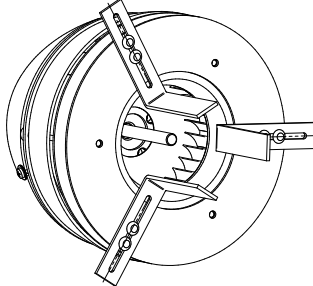
Step	Action	Illustration
1	<p>Measure the inside diameter of the brick chimney.</p> <p>Then cut a hole in the mineral wool mat that matches.</p> <p>Note that there must always be a minimum of 20 mm of mat surface at any point around the circumference of the hole.</p>	
2	<p>Fit the location brackets in the grooves on the underside of the bottom section and fasten using the nuts and bolts supplied.</p> <p>Please note that the bolts must be inserted from beneath.</p>	
3	<p>Adjust the distance between the location brackets to fit the inside diameter of the chimney, and then tighten the nuts. Note that there should be a 2-4 mm gap between the brackets and the chimney so as to avoid transmitting vibrations from the fan to the chimney.</p>	

4

Place the mineral wool mat on top of the chimney. It can be used with either of the sides facing the fan. The chimney fan can now be lowered into place (on top of the mat) with the location brackets into the chimney.

IMPORTANT! Do not screw or bolt the brackets into the flue pipe!

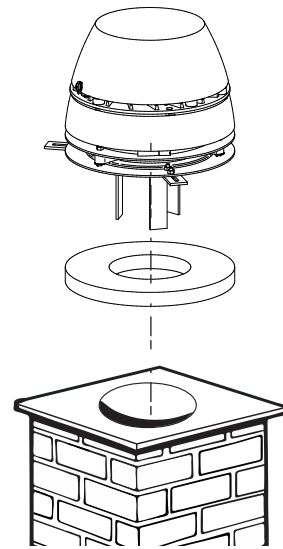

5

Before taking the fan into operation, please make sure that:

- the nuts in the location brackets have been tightened.
- the connection on the armoured cable has been fastened. The armoured cable must hang straight down from the fan.
- the chimney fan is securely closed.
- when opening/closing the fan, support the upper part with your hand.

NOTICE! The end-user should be made aware of the fact that the chimney fan must always remain switched on when the fireplace/boiler is in use.

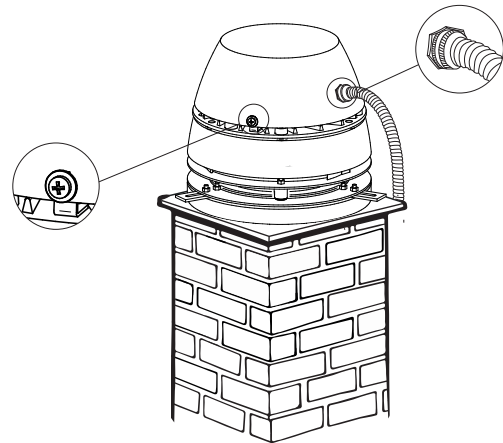

6

To avoid rainwater from entering the chimney fan the slots and holes must be sealed with heat resistant and fireproof silicone.

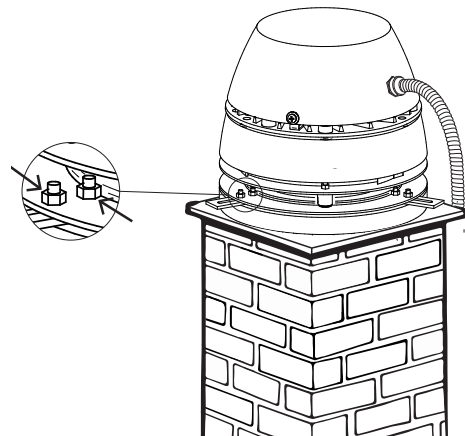

Installation onto a steel chimney

If the fan is to be fitted on a steel chimney, the chimney fan must be installed with an approved flange. See the installation guide below.

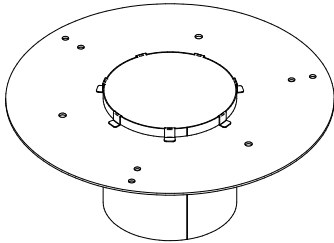
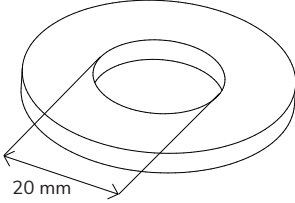
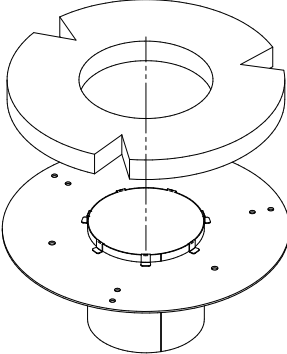
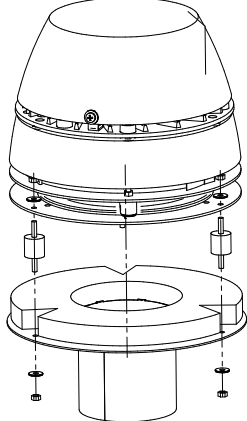
Step	Action	Illustration
1	<p>The flange must be placed so that the spigot goes into the chimney!</p> <p>Measure the diameter of the hole in the flange.</p>	
2	<p>Then cut a hole in the mineral wool mat that matches.</p> <p>Note that there must always be a minimum of 20 mm of mat surface at any point around the circumference of the hole.</p>	
3	<p>Cut the corners off the mineral wool mat, so there is room to fit the vibration dampers.</p> <p>If a temperature sensor is to be installed with the chimney fan, cut a groove in the mineral wool mat that is big enough for the sensor.</p> <p>Now place the mineral wool mat on the flange (between the flange and the fan).</p>	
4	<p>Fixate the flange to the chimney fan with the use of the vibration dampers supplied with the flange.</p>	

- 5 The fan assembly can now be fitted onto the steel chimney.

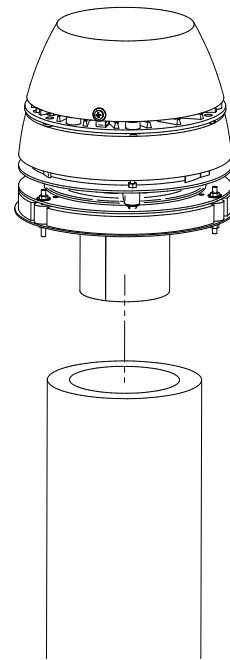

- 6
- the nuts in the flange have been tightened.
 - the connection on the armoured cable has been fastened. The armoured cable must hang straight down from the fan.
 - the chimney fan is securely closed.
 - when opening/closing the fan, support the upper part with your hand.

Before taking the fan into operation, please make sure that:

NOTICE! The end-user should be made aware of the fact that the chimney fan must always remain switched on when the fireplace/boiler is in use.

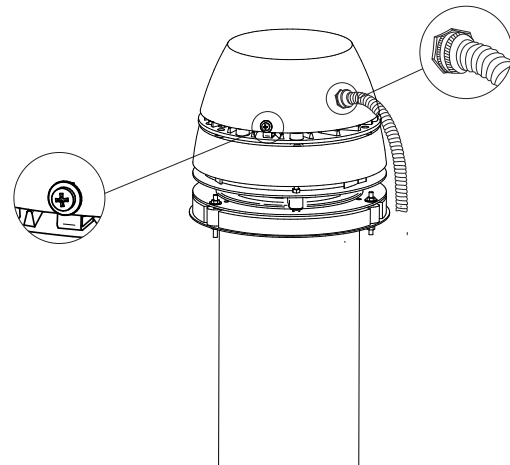

- 7
- To avoid rainwater from entering the chimney fan the slots and holes must be sealed with heat resistant and fireproof silicone.

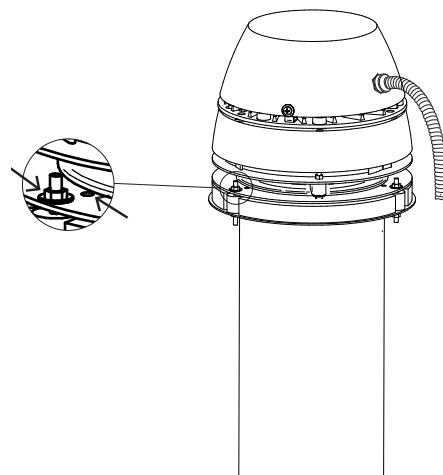

Multiple fans on chimney

If two or more chimney fans are required to create sufficient draft, installation procedures are almost the same as for single fan installation. See the installation guide below.

Multiple fans on a brick chimney

If two or more fans are required to create sufficient draft, a special adapter plate is required (not an Exodraft part). The two holes in the plate should match the throat diameter of the fan model used and the distance from center to center should be at least equal to the fan width. Exodraft recommends that a partition is mounted between the fans.

- 1 The adapter should be sealed with silicone and bolted onto the top. When installing multiple fans, it is extremely important that the fans are of the same model and size, and they must be controlled in tandem by one motor speed control.

A similar approach should be taken if the flue size exceeds the fan base dimensions. The adapter plate should be sized so it covers the flue and secured. A hole should be cut in the center of the plate and the fan mounted centered over the hole.

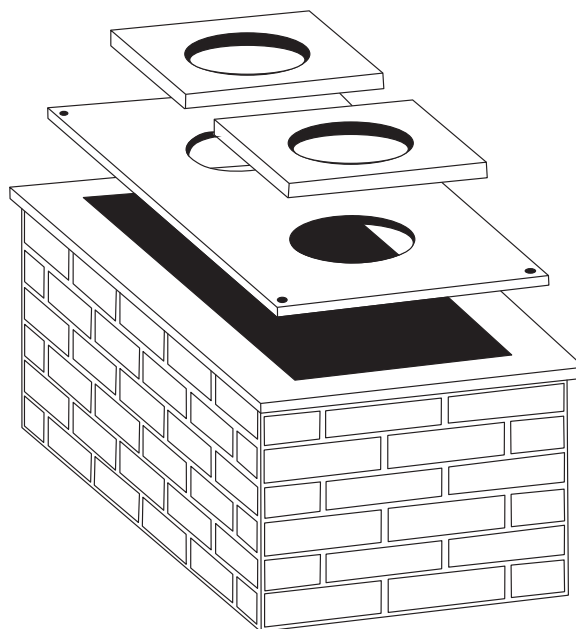

Multiple fans on a steel chimney

If two or more chimney fans are required to create sufficient draft, the installation procedures are basically the same as for single fan installation on a steel chimney. However, as the fans will be placed next to each other, a special plenum box will be required (not an Exodraft part).

- 1 Exodraft recommends that a partition is mounted between the fans. When installing multiple fans, it is extremely important that the fans are of the same model and size, and they must be controlled in tandem by one motor speed control.

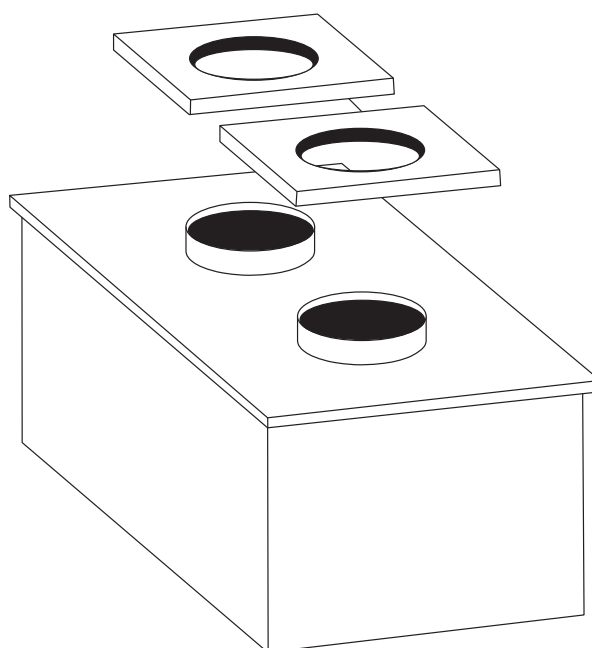

Electrical installation

The fan and motor specifications are provided on the fan's type plate. All the single-phased fan models are adjustable in speed.

Wires are to be connected in accordance the wiring diagram. For further details, please see guidelines for the Exodraft control units.

Any lightning conductor connected to the fan must respect current applicable national legislation.

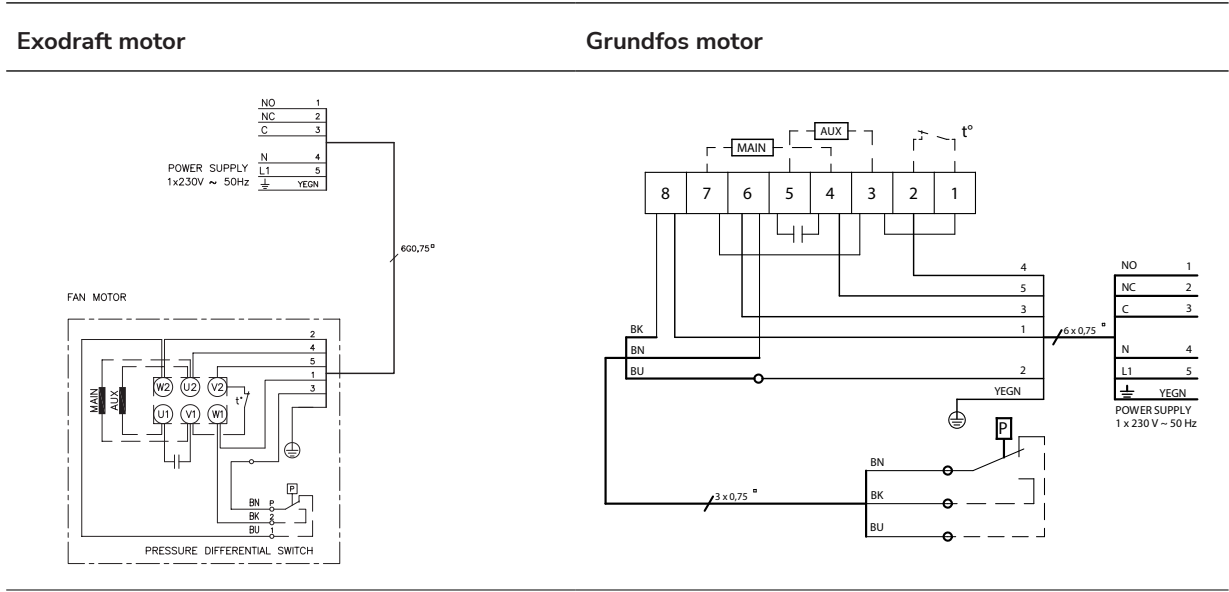

Isolation switch

In accordance with the provisions of the applicable EU Machinery Directive a combustion-gas fan must always have an isolation switch fitted. The isolation switch must comply with national wiring standards, and it must be ordered separately, as it is not part of the standard Exodraft scope of delivery.

Startup and configuration

System testing

Before any adjustments are made to the system, please follow these procedures:

Turn the chimney fan ON and make sure that it is turning. Increase and decrease the speed of the fan by adjusting the speed control to make sure the fan is operating properly.

After system testing, Exodraft recommends igniting your fireplace or stove. Follow the guide below for correct lighting and use of the chimney fan.

Operating the fireplace using the EFC21 controller

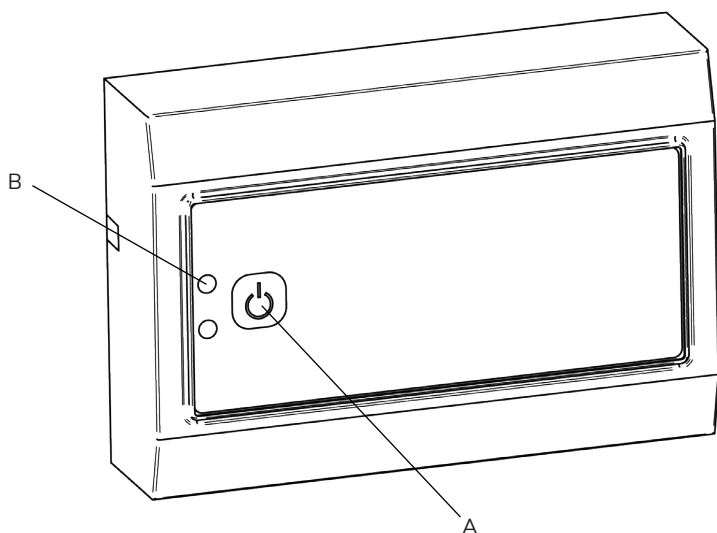

Press the ON/OFF button

- The operating LED **(B)** will flash GREEN until the correct chimney draught is confirmed. If it flashes YELLOW, then the Air inlet must be opened. The operating LED will then become GREEN and the fireplace can be lit.
- To stop the fan press the ON/OFF **(A)** button.

External ON/OFF switch

- The ON/OFF **(A)** switch can be used to start, stop and reset the controller.
- If the external ON/OFF **(A)** switch is used, it has priority over the control panel and the remote control

Note! The switch must be in the OFF position before the controller can be re-started.



DANGER! Check that the heating appliance (water heater, furnace, etc.) is working properly after the chimney fan has been switched on. Make sure that no flue gases are spilling out as this can lead to carbon monoxide poisoning!

Testing flue gas extraction and the pressure switch setting

This test must be carried out to ensure that the pressure switch (PDS) and the speed of the chimney fan have been adjusted correctly for the unit in question. The test must be carried out with doors and windows closed. If other extraction fans have been installed, these must be switched on during the test.

Test procedure

If flue gases enter the room, the speed of the chimney fan must be increased. If flue gases enter the room without the failsafe system shutting off the gas supply, the pressure switch (PDS) must be adjusted to a higher setting.

If the sound pressure level is very high, reduce the speed of the chimney fan. Then perform the test once more and repeat this procedure if necessary. The procedure must always be concluded with a test.

During such a test, all windows and doors must be closed and any ventilation fans switched on. Please refer to the relevant Exodraft Gas Fan Controller Installation Instructions for guidance. Remove the top cover and adjust the (PDS) to the required value.



WARNING! Do not open the top section unless the power to the chimney fan has been disconnected!

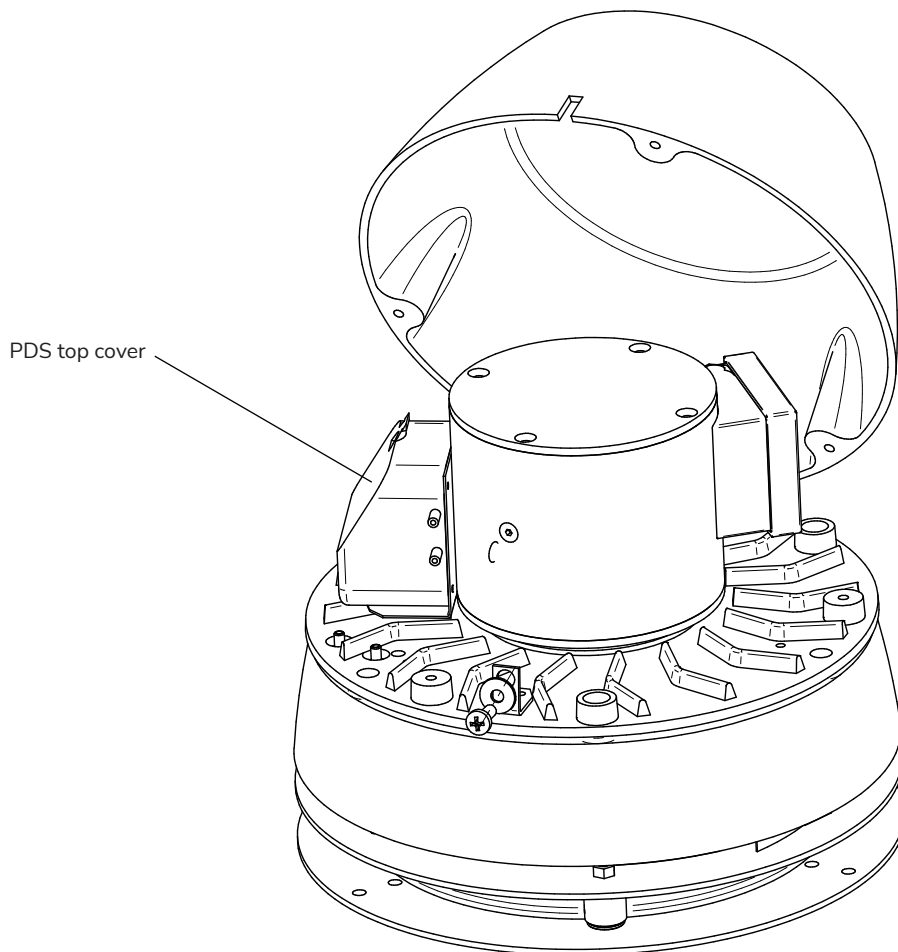

Maintenance and troubleshooting

Care and cleaning

It is extremely important to keep the flue clean from creosote and deposits as soot is the major cause of chimney fires. The top of the fan is hinged and can be opened to ensure easy cleaning of the fan.

Cleaning intervals depend on the use of the fireplace. The more the appliance is used, the more often the chimney flue must be cleaned. If a fireplace is used regularly (2-3 times a week), a semi-annual cleaning of the chimney and the fan may be required. If used on a daily basis shorter intervals may apply.

No matter how often the fan is used, the fan must be inspected and cleaned at least once a year – for instance when the chimney is inspected and cleaned by your chimney sweep. The chimney should always be cleaned by a trained professional chimney sweep.

Gas appliances should be checked for safety once a year by an installer registered in the Gas Safe register.

Note!

The motor in the fan has ball bearings that are sealed, lifetime lubricated and maintenance-free.

Should replacement of the bearings be required, this should be carried out by properly qualified personnel only.

Cleaning procedure

Step	Action
1	Use the isolation switch to switch off the power to the fan and make sure the fan doesn't rotate.
2	Loosen the screw and open the top section of the fan.
3	Dismantle the chimney fan as shown here.
4	During this service procedure, all soot deposits must be removed from the centrifugal impeller and the sensors.
5	Be very careful not to damage the flue gas measuring system.

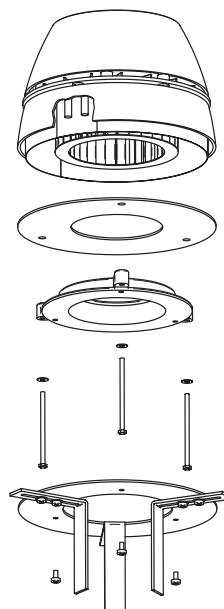

WARNING! Do not open the motor housing unless the power to the chimney fan has been disconnected!



WARNING! The flow sensors must not be bent or moved, as this might affect their performance.

Troubleshooting

Observation	Problem	Solution
<i>There is no power to the fan</i>	The isolation switch may be on off	Check isolation switch
	The speed control is turned off	Turn speed control on
	Loose electrical connection	Check wiring and correct problem
<i>There is power to the fan but it is not working</i>	Loose electrical connections	Check wiring and correct problems with connections. Pay special attention to the wiring in the junction box
	The voltage setting is too low	Increase the speed setting
<i>There is power to the fan but it hums and does not turn</i>	The capacitor may be worn out	Check capacitor and replace if necessary
	Soot makes the impeller stick	Clean the fan
<i>The fan seems to work fine, but there is not enough draught</i>	The fan may be undersized	Replace with a larger fan
	The capacitor may be worn out	Check capacitor and replace if necessary
	The flue is damaged/blocked	Check the flue (chimney sweep)
<i>The fan vibrates</i>	The motor shaft may be bent	Replace motor
	The fan needs cleaning	Clean the fan
	Incorrect installation	Check installation guide in this manual
<i>There is airflow noise from the fireplace opening</i>	The fan is running too fast	Reduce the fan speed
<i>Mechanical noise can be heard</i>	Soot or tar may impair the impeller	Clean the impeller
	Motor bearings may be worn out/over-heated	Replace bearings
	Incorrect installation	Check installation guide in this manual



UK Conformity Assessed



**Exodraft a/s
Industrivej 10
DK-5550 Langeskov**

Hereby declares that the following products:

RHG160

Were manufactured in conformity with the provisions of the following regulations:

The Supply of Machinery (Safety) Regulations 2008

Electrical Equipment (Safety) Regulations 2016

Electromagnetic Compatibility Regulations 2016

Langeskov, 01-11-2022
Managing Director
Anders Haugaard



Declaration of Conformity

DK: EU-Overensstemmelseserklæring
 GB: Declaration of Conformity
 DE: EU-Konformitätserklärung
 FR: Déclaration de conformité de l'Union Européenne
 NO: EU-Samsvarserklæring
 PL: EU Deklaracja zgodności

NL: EU-Conformiteits verklaring
 SE: EU-Överensstämmelsedeklaration
 FI: EU-Vaatimustenmukaisuusvakuutus
 IS: ESS-Samræmisstaðfesting
 IT: Dichiarazione di Conformità Unione Europea

Exodraft a/s
Industrivej 10
DK-5550 Langeskov

Erklærer på eget ansvar, at følgende produkter:
 Hereby declares that the following products:
 Erklärt hierdurch auf eigene Verantwortung, daß folgende Produkte:
 Déclare, sous sa propre responsabilité, que les produits suivants:
 Erklærer på eget ansvar at følgende produkter:
 Niniejszym oświadczam, że następujące produkty:

Veklaart dat onderstaande producten:
 Deklarerar på eget ansvar, att följande produkter:
 Vastaa siltä, että seuraava tuote:
 Staðfesti à eigin àbyrgð, að eftirfarandi vörur:
 Dichiaro con la presente che i seguenti prodotti:

RHG160

Som er omfattet af denne erklæring, er i overensstemmelse med følgende standarder:
 Were manufactured in conformity with the provisions of the following standards:
 Die von dieser Erklärung umfaßt sind, den folgenden Normen:
 Auxquels s'applique cette déclaration sont en conformité avec les normes ci-contre:
 Som er omfattet av denne erklæring, er i samsvar med følgende standarder:
 Zostały wyprodukowane zgodnie z warunkami określonymi w następujących normach:

Zijn vervaardigd in overeenstemming met de voorschriften uit de hieronder genoemde normen en standaards:
 Som omfattas av denna deklaration, överensstämmer med följande standarder:
 Jota tämä selvitys koskee, on seuraavien standardien mukainen:
 Sem eru meðtalin í staðfestingu Pessari, eru í fullu samræmi við eftirtalda staðla:
 Sono stati fabbricati in conformità con le norme degli standard seguenti:

EN 60335-1, EN 60335-2-80, DS/EN ISO 12100: 2011

I.h.t bestemmelser i direktiv:
 In accordance with
 Entsprechen gemäß den Bestimmungen der folgenden Richtlinien:
 Suivant les dispositions prévues aux directives:
 I.h.t bestemmelser i direktiv:
 Zgodnie z:

En voldoen aan de volgende richtlijnen:
 Enligt bestämmelserna i följande direktiv:
 Seuraavien direktiivien määräysten mukaan:
 Med tilvisun til ákvarðana eftirlits:
 In conformità con le direttive:

Maskindirektivet:
 The Machinery Directive:
 Richtlinie Maschinen:
 Directive Machines:
 Maskindirektivet:
 Dyrektywę maszynową:

De machinerichtlijn:
 Maskindirektivet
 Konedirektiivi:
 Vèlaeftirlitið:
 Direttiva Macchinari:

2006/42/EF-EEC/-EWG/-CEE

Lavspændingsdirektiv:
 The Low Voltage Directive:
 Niederspannungsrichtlinie:
 Directive Basse Tension:
 Lavspændingsdirektivet:
 Dyrektywę Niskonapięciową

De laagspanningsrichtlijn:
 Lågspänningsdirektivet:
 Pienjännitedirektiivi:
 Smáspennueftirlitið:
 Direttiva Basso Voltaggio:

2014/35/EC

EMC-direktivet:
 And the EMC Directive:
 EMV-Richtlinie:
 Directive Compatibilité Electromagnétique:
 EMC-direktivet:
 Dyrektywę EMC – kompatybilności elektromagnetycznej

En de EMC richtlijn:
 EMC-direktivet:
 EMC-direktiivi:
 EMC-efirlitið:
 Direttiva Compatibilità Elettromagnetica:

2014/30/EC

Langeskov, 01-11-2022
 Adm. direktør
 Managing Director
 Anders Haugaard

Algemeen directeur
 Geschäftsführender Direktor
 Président Directeur Général
 Verkställande direktör
 Toimitusjohtaja
 Framkvemdastjóri
 Direttore Generale

DK: Exodraft a/s

Industrivej 10
DK-5550 Langeskov
Tel: +45 7010 2234
Fax: +45 7010 2235
info@exodraft.dk
www.exodraft.dk

SE: Exodraft a/s

Valhallavägen 9A
SE-375 30 Mörrum
Tel: +46 (0)8-5000 1520
info@exodraft.se
www.exodraft.se

NO: Exodraft a/s

Storgaten 88
NO-3060 Svelvik
Tel: +47 3329 7062
info@exodraft.no
www.exodraft.no

UK: Exodraft Ltd.

24 Janes Meadow, Tarleton
GB-Preston PR4 6ND
Tel: +44 (0)1494 465 166
Fax: +44 (0)1494 465 163
info@exodraft.co.uk
www.exodraft.co.uk

DE: Exodraft a/s

Niederlassung Deutschland
Industriestraße 14
DE-55768 Hoppstädten-Weiersbach
Tel: +49 6782 989 590
Fax: +49 6782 989 5929
info@exodraft.de
www.exodraft.de

FR: Exodraft sas

78, rue Paul Jozon
FR-77300 Fontainebleau
Tel: +33 (0)6 3852 3860
info@exodraft.fr
www.exodraft.fr

Your energy. Optimized.

exodraft